

PROFESSIONAL STAGE & STUDIO EQUIPMENT



www.fortlamps.ru +7495 749 66 09 info@fortlamps.ru

KUPO[®]

PROFESSIONAL STAGE & STUDIO EQUIPMENT PROVIDER

WHO WE ARE

KUPO is one of the leading hardware solutions providers in the entertainment industry. We design, manufacture and distribute sophisticated products, including lighting and camera support, power connection, gear protection case, shopfitting display, lifting equipment and control systems.

For more than four decades, KUPO has established a well-recognized reputation for quality and innovation. Our customers are around the globe who work behind the scenes as the photographer, video and cine image-provider, theatre, concert hall, touring crews, and lighting designers. KUPO has forged its own path to the world by crafting innovative tools with unparalleled quality, sought after and shaped by industry professionals worldwide. To meet these professionals' needs, we offer numerous patent products including quick release and locking C-stand, multi direction easy storage Click Stand, auto self-locking Wind-up stand, lever lock and release device for Kupole, anti-slip rosettes friction disc of Max Arms, quick action Telescopic Hanger and the list goes on. All KUPO products have been painstakingly machined so you know you can count on their incredible strength and durability in harsh production environments. They are so durable, in fact, that they create a history of their own through their many years of service. Moreover its reliability is credited for certificates such as TUV-GS, CE, UL and CUL for several electrical products and the most popular Wind-up stand, Clamps, Couplers and Safety Wire.

OUR DRIVING FORCE

Our commitment to improvement is constant, we dedicate ourselves in creating Humanism, Quality, Invention and Safety to our people (both employee and customer), and our environment also to the booming content creation market. To those who work behind the scenes and stages, we consider you, the content creator, a partner, integral to our innovative process. We greatly value your experience and listen carefully to both your needs and desires, which inspires us to create better tools to empower your professionals to capture and share exceptional content. Enjoy your ride with us, when it comes to helping you achieve your vision dream with KUPO equipment,

**WE LIKE TO SAY AT KUPO:
*NEVER LET GO***



**YOUTUBE
KUPO FACTORY
INTRODUCTION VIDEO**

LIGHTING FIXTURE INDEX

Mini LED Profile Spot	204
Mini LED Prism Convex Spot Light	205
Compact LED Fresnel	206
Compact LED Profile Spot	207
Compact LED Zoom Profile Spot	208
Aqua 280 LED Profile Spot	209
Solar 350 LED Profile Spot	210
Motorized LED Fresnel	211
LED Cyclorama	212 - 213
LED Outdoor Par	214
LED Par Can	215 - 216
LED Megapar & Mini Mega Par	217
LED Zoom Profile	218
LED Event Spot	219 - 220
LED Pixel Strip	221
Tungsten Junior	222
Mega Lite	223
Mega Par & Mega mix	224
Par Can	225 - 226
Cyclorama & Flood Light	227 - 228
Fresnel & Prism Convex	229 - 230
Audience Blinder	231 - 232
Followspot	233 - 234
LED Par 16-20-30	235
LED Shop Light	236
LED Gobo Projector	237
Mini Image Projector	238
Track & Accessories	239
Pole-operated Yoke	240
Telescopic Operating Pole	241
IRIS	242 - 244
Lighting Control Accessories	245 - 247
Dichroic Filter	248 - 250
Honeycomb	251
Gooseneck Lamp	252
Lighting Control System	253 - 254
DMX Tester	255
Digi Fan	256 - 257
Mirror Ball & Motor	258
Goreal Intercom	259 - 260

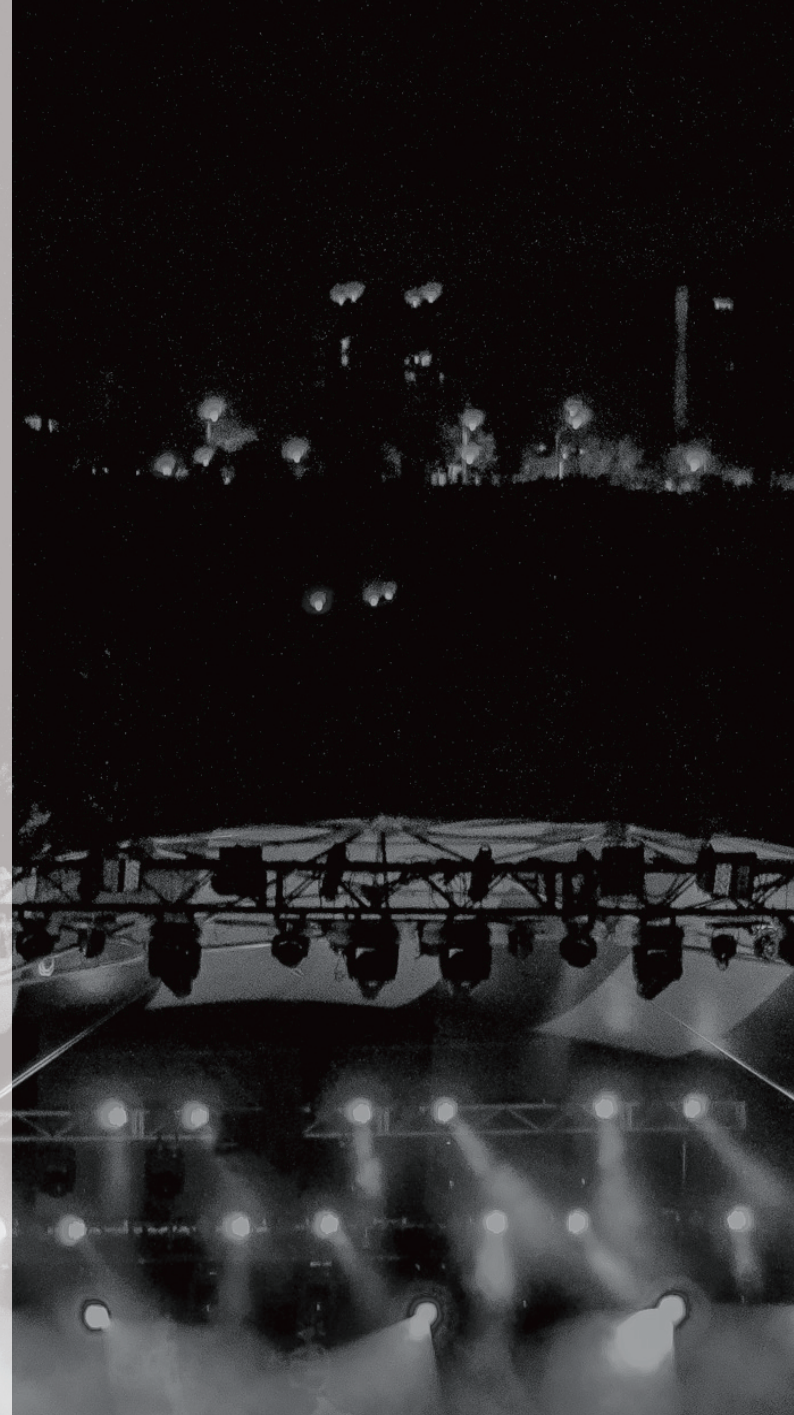

Content

Kupo is a leading producer of professional lighting fixtures for theatre, events, and concerts. We have various lighting fixtures available, including the conventional par can, audience blinder, cyclorama & flood light, Fresnel & Prism Convex, Xenon followspot, to the newly-launched Tungsten junior series, Megapar & Megalite, event spot and fixture with discharge lamp source.

Come and join us on www.stage.com.tw

Mini LED profile spot comes with a 20W COB LED engine in very compact size, making this small luminaire stunning for its powerful light output. Constructed of thermoplastic front lens tube and the aluminum rear housing, this 2-channel luminaire is tiny yet durable. Similar to classic profile spot, mini LED profile spot is available in 14, 19, 26, 36 degree. The LED has a lifespan exceeding 50,000 hours.



Specification

- Power Input: AC100-240V, 50/60Hz
- Power Consumption: 22W
- LED Source: COB LED 20W
- Control: 2 channel (dimming & strobe) via DMX-512
- Luminous Flux: 1950-2535lm
- Beam Angle: 14°, 19°, 26°, 36° available
- Color Temperature: 3200K(Warm White) or 5700K(Daylight)
- CRI: ≥93Ra
- Protection grade: IP20
- Working environment: -20°C ~ 45°C
- N.W.: 1.1kg
- G.W: 1.6kg
- Dimension: 250(L) x 130 (W) x 143(H)/mm
- Please specify 3pin or 5pin XLR connector while placing the order.
- For **5700K daylight** / **RGBW** version, the item number will come with **D** / **C** in the suffix.

ZML-2214**DC** Mini LED Profile Spot
20W, 3200K/ 5700K/ RGBW, 14 degree

ZML-2219**DC** Mini LED Profile Spot
20W, 3200K/ 5700K/ RGBW, 19 degree

ZML-2226**DC** Mini LED Profile Spot
20W, 3200K/ 5700K/ RGBW, 26 degree

ZML-2236**DC** Mini LED Profile Spot
20W, 3200K/ 5700K/ RGBW, 36 degree

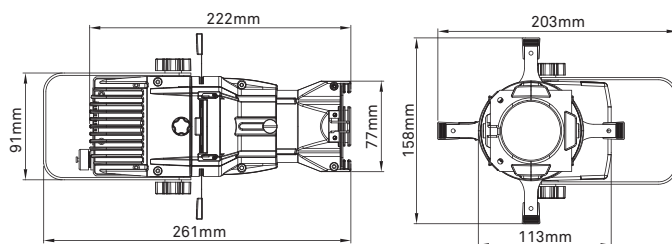

Photometric

Beam Angle	Throw Distance (M)	1M	2M	3M	4M	5M
14 degree	Field Diameter (M)	0.22	0.47	0.71	0.94	1.18
	Illuminance (Lux)	10260	2224	961	541	349
19 degree	Field Diameter (M)	0.30	0.64	0.96	1.28	1.60
	Illuminance (Lux)	6167	1325	592	332	214
26 degree	Field Diameter (M)	0.42	0.86	1.32	1.74	2.18
	Illuminance (Lux)	5420	1246	543	306	199
36 degree	Field Diameter (M)	0.61	1.24	1.93	2.48	3.11
	Illuminance (Lux)	4382	935	425	241	155



Portable, palm-size, and extremely lightweight. Ideal for retail shop, restaurant, art gallery and museum.



Superior optics and powerful COB light engine gives a great light output. Pattern holder included; feasible for dia. 18mm image size



It's totally noise free. Aluminum die-cast rear housing helps up with cooling the working heat. No fan, no noise!



DMX in/out for the convenience signal transmission. LED display makes it easy to set up the address channel

Mini LED prism convex spot light comes with a 20W COB LED engine in very compact size, making this small luminaire stunning by its powerful light output. Constructed of thermoplastic front barrel and the aluminum rear housing, this 2-channel luminaire is tiny yet durable. Available in 10°, 20°, 30°, and 40° beam angels. The LED has a lifespan exceeding 50,000 hours.



Specification

- Power Input: AC100-240V, 50/60Hz
- Power Consumption: 22W
- LED Source: COB LED 20W
- Control: 2 channel (dimming & strobe) via DMX-512
- Luminous Flux: 1950-2535lm
- Beam Angle: 10°, 20°, 30°, 40° available
- Color Temperature: 3200K(Warm White) or 5700K(Daylight)
- CRI: ≥93Ra
- Protection grade: IP20
- Working environment: -20°C ~ 45°C
- N.W.: 1.0kg
- G.W: 1.5kg
- Dimension: 250(L) x 130 (W) x 143(H)/mm
- Please specify 3pin or 5pin XLR connector while placing the order.
- For 5700K daylight / RGBW version, the item number will come with **D** / **C** in the suffix.

ZPS-2210**D****C** Mini LED Prism Convex Spot Light
20W, 3200K/ 5700K/ RGBW, 10 degree

ZPS-2220**D****C** Mini LED Prism Convex Spot Light
20W, 3200K/ 5700K/ RGBW, 20 degree

ZPS-2230**D****C** Mini LED Prism Convex Spot Light
20W, 3200K/ 5700K/ RGBW, 30 degree

ZPS-2240**D****C** Mini LED Prism Convex Spot Light
20W, 3200K/ 5700K/ RGBW, 40 degree

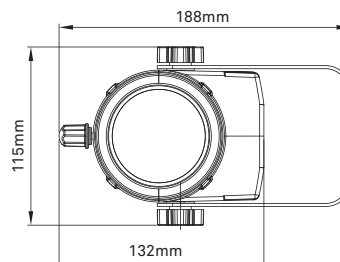
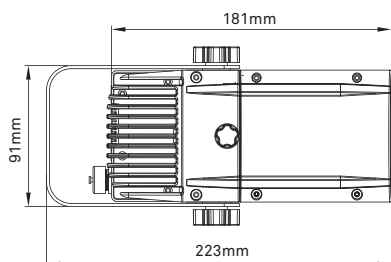

Portable, palm-size, and extremely lightweight. Ideal for retail shop, restaurant, art gallery and museum.

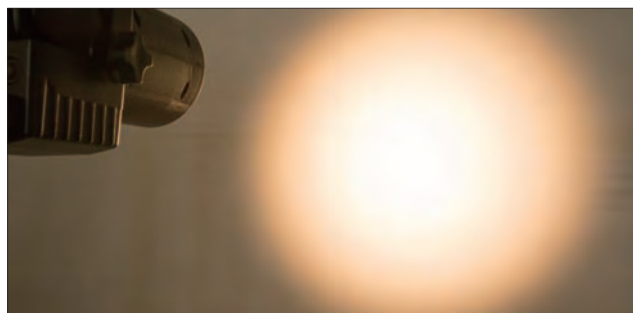

Prism convex lens and powerful COB light engine gives a great light output.



It's totally noise free. Aluminum die-cast rear housing helps up with cooling the working heat. No fan, no noise!



DMX in/out for the convenience signal transmission. LED display makes it easy to set up the address channel.

ZFS is a mini LED wash fixture built with 50W COB LED and Fresnel lens. Thermoplastic housing makes it lightweight and handy to operate. Projection angle is manually adjustable from 15 to 45 degree. With add-on signal box, it can be dimmed and controlled by DMX-512. The LED has a lifespan exceeding 50,000 hours.

Specification

- Power Input: AC100-240V, 50/60Hz
- Power Consumption: 65W
- LED Source: COB LED 50W
- Control: on/off, or DMX-512 through add-on signal box
- Luminous Flux: 3440-4158lm
- Beam Angle: 15° ~45°
- Color Temperature: 3000K or 5700K
- CRI: ≥ 93 Ra
- Protection grade: IP20
- Working environment: -20°C ~ 45°C
- N.W.: 1.8kg
- G.W.: 2.5kg
- Dimension: 380(L) x 195 (W) x 195(H)/mm
- Please specify 3pin or 5pin XLR connector while making order.



ZFS-65 Compact LED Fresnel Light
65W Compact Led Fresnel Light, 3200K Warm White

ZFS-65D Compact LED Fresnel Light
65W Compact Led Fresnel Light, 5700K Daylight

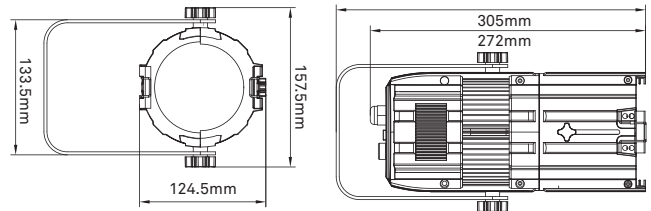

Photometric

Beam Angle	Throw Distance (M)	1M	2M	3M	4M	5M	6M	7M	8M
15 degree	Illuminance (Lux)	36580	8588	3714	2065	1283	875	651	495
45 degree	Illuminance (Lux)	8351	2095	1007	585	374	235	178	139



Add-on signal box is a 2 channels control device, for dimming and strobe through DMX-512. Available with 3pin or 5pin XLR. It also has a knob for manual dimming .



The add-on box is detachable from the luminaire, turning dimming mode to on/off running mode. Power daisy linkup for the operation convenience.



Thermoplastic housing makes the luminaire lightweight; aluminum heat-sink is centrally located helping reduce the LED working heat.



4-leave barndoor is supplied as standard accessory for lighting control.

Compact LED profile spot comes with a 50W COB LED engine in small dimensions, making this luminaire stunning for its powerful light output. Constructed of thermoplastic front lens tube and rear housing, having the fixture lightweight and handy. Similar to classic profile spot, this luminaire is available in 19, 26, 36, 50 degree. The LED has a lifespan exceeding 50,000 hours.



Specification

- Power Input: AC100-240V, 50/60Hz
- Power Consumption: 65W
- LED Source: COB LED 50W
- Control: on/off, or 2 channel (dimming & strobe) via add-on DMX-512 signal box
- Luminous Flux: 3440-4158lm
- Beam Angle: 19°, 26°, 36°, 50° available
- Color Temperature: 3200K(Warm White) or 5700K(Daylight)
- CRI: ≥93Ra
- Protection grade: IP20
- Working environment: -20°C ~ 45°C
- N.W.: 1.8kg
- G.W.: 2.5kg
- Dimension: 380(L) x 195 (W) x 195(H)/mm
- Please specify 3pin or 5pin XLR connector while placing the order.
- For **5700K daylight** version, the item number will come with **D** in the suffix.

ZML-6519D Compact LED Profile Light
65W, 3200K/ 5700K, 19 degree

ZML-6526D Compact LED Profile Light
65W, 3200K/ 5700K, 26 degree

ZML-6536D Compact LED Profile Light
65W, 3200K/ 5700K, 36 degree

ZML-6550D Compact LED Profile Light
65W, 3200K/ 5700K, 50 degree

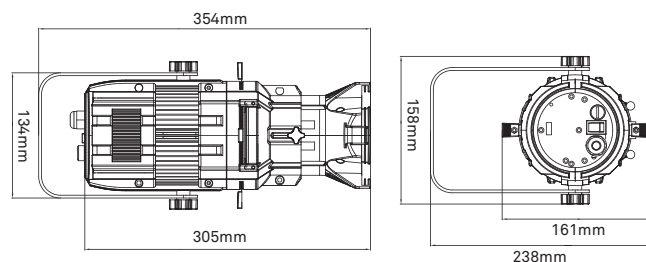

Photometric

Beam Angle	Throw Distance (M)	1M	2M	3M	4M	5M	6M	7M	8M
19 degree	Field Diameter (M)	0.33	0.67	1.00	1.34	1.67	2.00	2.34	2.68
	Illuminance (Lux)	27400	5444	2354	1305	907	599	423	322
26 degree	Field Diameter (M)	0.46	0.92	1.39	1.85	2.31	2.77	3.23	3.69
	Illuminance (Lux)	14440	3025	1324	737	496	341	249	193
36 degree	Field Diameter (M)	0.65	1.3	1.95	2.6	3.25	3.9	4.55	5.2
	Illuminance (Lux)	8815	1832	820	461	307	234	181	140
50 degree	Field Diameter (M)	0.93	1.87	2.8	3.73	4.66	5.6	6.53	7.46
	Illuminance (Lux)	4091	848	381	225	169	128	96	73

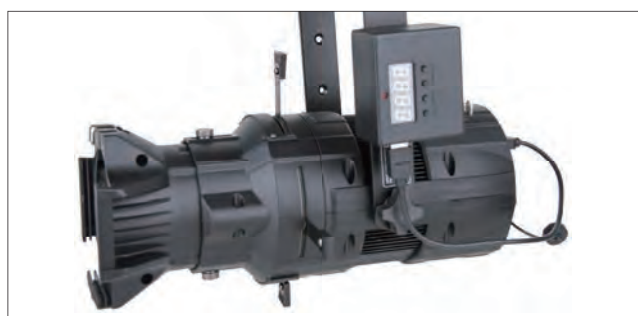

Lightweight and portable. Ideal for retail shop, restaurant, art gallery and museum.

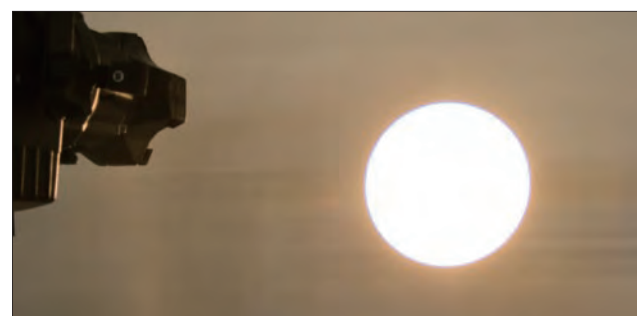

Superior optics and powerful COB light engine gives a great light output. Pattern holder included; feasible for dia. 25mm image size.



Aluminum extruded heat-sink is located in the central for better heat regulation.



An add-on box attached to the yoke for the convenience of DMX control. LED display makes it easy to set up the address channel.

Compact LED zoom profile spot comes with a 50W COB LED engine in a slim and neat profile. Housing is made of aluminum alloy, keeping the luminaire lightweight. Beam angle can be manually adjusted from 19° to 36°, making the adjustment of image projection much flexible. The LED has a lifespan exceeding 50,000 hours.

Specification

- Power Input: AC100-240V, 50/60Hz
- Power Consumption: 65W
- LED Source: COB LED 50W
- Control: on/off, or 2 channel (dimming & strobe) via add-on
- DMX-512 signal box
- Luminous Flux: 3440-4158lm
- Beam Angle: 19°-36° adjustable
- Color Temperature: 3200K(Warm White) or 5700K(Daylight)
- CRI: ≥ 93 Ra
- Protection grade: IP20
- Working environment: -20°C ~ 45°C
- N.W.: 2.9kg
- G.W: 3.6kg
- Dimension: 380(L) x 195 (W) x 195(H)/mm
- Please specify 3pin or 5pin XLR connector while placing the order.
- For **5700K daylight** version, the item number will come with **D** in the suffix.



ZML-Z1936D Compact LED Zoom Profile Spot
65W, 3200K/ 5700K, 19-36 degree adjustable

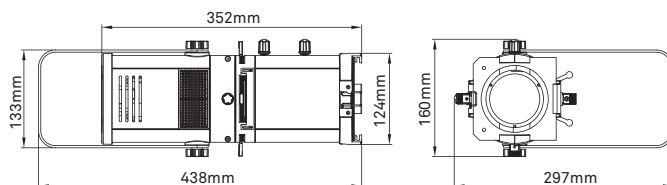

Photometric

Beam Angle	Throw Distance (M)	1M	2M	3M	4M	5M	6M	7M	8M
19 degree	Field Diameter (M)	0.33	0.67	1.00	1.34	1.67	2.00	2.34	2.68
	Illuminance (Lux)	21680	5649	2638	1286	844	565	401	321
36 degree	Field Diameter (M)	0.65	1.3	1.95	2.6	3.25	3.9	4.55	5.2
	Illuminance (Lux)	7933	1791	865	472	293	223	174	137



Aluminum housing with ventilation slots makes the luminaire lightweight and good for working temperature control.



Superior optics and powerful COB light engine gives a great light output. Pattern holder included; feasible for dia. 25mm image size.



Two handles at front barrel are for the convenience of beam adjustment. Four shutters help to regulate the beam shape.



An add-on box attached to the rear housing for manual dimmer or DMX control. LED display makes it easy to set up the address channel.

Aqua 280 LED profile spot is the luminaire with IP65 rated, ideal for the applications where there will be water ingress or humidity concerns. Come with a 250W COB LED engine, making this luminaire powerful lighting output. Available in full range of lens tube, 19°, 26°, 36°, and 50°, for the comprehensive application. The LED has a lifespan exceeding 50,000 hours.



Specification

- Power Input: AC100-240V, 50/60Hz
- Power Consumption: 280W
- LED Source: COB LED 250W
- Control: 2 channel (dimming & strobe)
- Luminous Flux: 32750-34250lm
- Beam Angle: available in 19°, 26°, 36°, 50°
- Color Temperature: 3200K(Warm White) or 5600K(Daylight)
- CRI: ≥90Ra
- Protection grade: IP65
- Working environment: -20°C ~ 40°C
- N.W.: 10.5kg
- G.W.: 13.0kg
- Dimension: 740(L) x 285 (W) x 320(H)/mm
- Please specify 3pin or 5pin XLR connector while placing the order.
- For 5600K daylight version, the item number will come with **D** in the suffix.
- RGBW version depend on request.

ZML-28019PD**** AQUA 280 LED Profile Spot

280W, 3200K/ 5600K, 19 degree, IP65

ZML-28026PD**** AQUA 280 LED Profile Spot

280W, 3200K/ 5600K, 26 degree, IP65

ZML-28036PD**** AQUA 280 LED Profile Spot

280W, 3200K/ 5600K, 36 degree, IP65

ZML-28050PD**** AQUA 280 LED Profile Spot

280W, 3200K/ 5600K, 50 degree, IP65

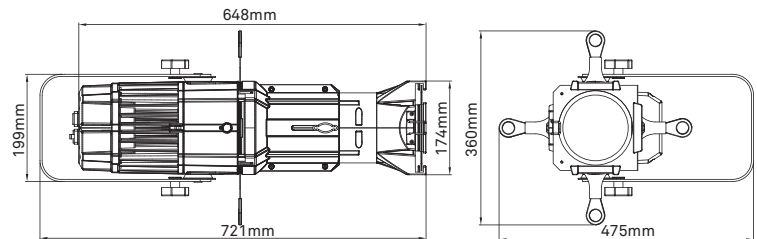

Photometric

Beam Angle	Throw Distance (M)	1M	2M	3M	4M	5M	6M	7M	8M	9M	10M
19 degree	Field Diameter (M)	0.33	0.67	1.00	1.34	1.67	2.00	2.34	2.68	3.01	3.35
	Illuminance (Lux)	487800	64572	26196	13884	8535	5834	4250	3268	2635	2061
26 degree	Field Diameter (M)	0.46	0.92	1.39	1.85	2.31	2.77	3.23	3.69	4.16	4.62
	Illuminance (Lux)	295620	42132	17580	9489	5907	4108	3018	2350	1983	1714
36 degree	Field Diameter (M)	0.65	1.3	1.95	2.6	3.25	3.9	4.55	5.2	5.85	6.5
	Illuminance (Lux)	190380	31608	13752	7513	4637	3318	2473	2357	1673	1379
50 degree	Field Diameter (M)	0.93	1.87	2.8	3.73	4.66	5.6	6.53	7.46	8.39	9.33
	Illuminance (Lux)	83136	16416	7278	4225	2726	2005	1522	1211	949	753

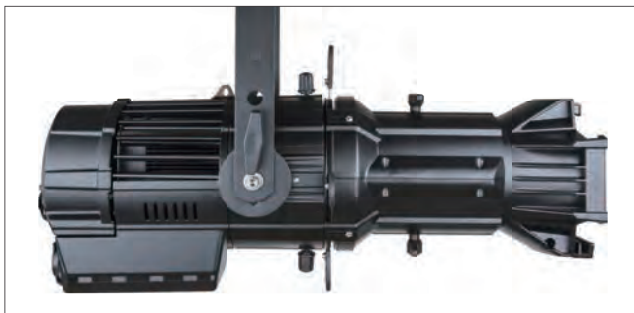

Aluminum heat-sink and housing makes the luminaire lightweight and good for working temperature control.



Constructed with IP65 rated for the toughness environment. Feasible with standard ETC accessories for the light control.



Great performance with linear dimming 0-100%. Data and power connectors are also IP65 rated with protective cover. Navigating the setting is convenient through LCD control touch panel.

Solar 350 LED profile spot comes with a 300W COB LED engine, a very powerful light source for theatrical applications in the market. The option of several lens tubes, like classic profile spot, makes it feasible for the request of diverse lighting beam angles. Made of aluminum housing for the maximum toughness. The LED has a lifespan exceeding 50,000 hours.



Specification

- Power Input: AC100-240V, 50/60Hz
- Power Consumption: 350W
- LED Source: COB LED 300W
- Control: 2 channel (dimming & strobe)
- Luminous Flux: 30000-33000lm
- Beam Angle: available in 19°, 26°, 36°, 50°
- Color Temperature: 3200K or 5600K
- CRI: ≥90Ra
- Protection grade: IP20
- Working environment: -20°C ~ 45°C
- N.W.: 10.5kg
- G.W: 13.8kg
- Dimension: 770(L) x 330 (W) x 340(H)/mm
- Please specify 3pin or 5pin XLR connector while placing the order.
- For **5600K daylight** version, the item number will come with **D** in the suffix.

ZML-35019D SOLAR 350 LED Profile Spot
350W, 3200K/ 5600K, 19 degree

ZML-35026D SOLAR 350 LED Profile Spot
350W, 3200K/ 5600K, 26 degree

ZML-35036D SOLAR 350 LED Profile Spot
350W, 3200K/ 5600K, 36 degree

ZML-35050D SOLAR 350 LED Profile Spot
350W, 3200K/ 5600K, 50 degree

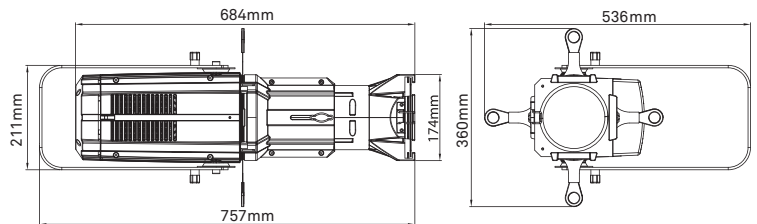

Photometric

Beam Angle	Throw Distance (M)	1M	2M	3M	4M	5M	6M	7M	8M	9M	10M
19 degree	Field Diameter (M)	0.33	0.67	1.00	1.34	1.67	2.00	2.34	2.68	3.01	3.35
	Illuminance (Lux)	569100	75334	30562	16198	9950	6808	4958	3820	3075	2638
26 degree	Field Diameter (M)	0.46	0.92	1.39	1.85	2.31	2.77	3.23	3.69	4.16	4.62
	Illuminance (Lux)	344540	49154	20510	11060	6890	4802	3521	2744	2313	1999
36 degree	Field Diameter (M)	0.65	1.3	1.95	2.6	3.25	3.9	4.55	5.2	5.85	6.5
	Illuminance (Lux)	222110	36876	16044	8765	5410	3871	2885	2750	1952	1609
50 degree	Field Diameter (M)	0.93	1.87	2.8	3.73	4.66	5.6	6.53	7.46	8.39	9.33
	Illuminance (Lux)	96992	19152	8491	4929	3180	2339	1775	1413	1107	878

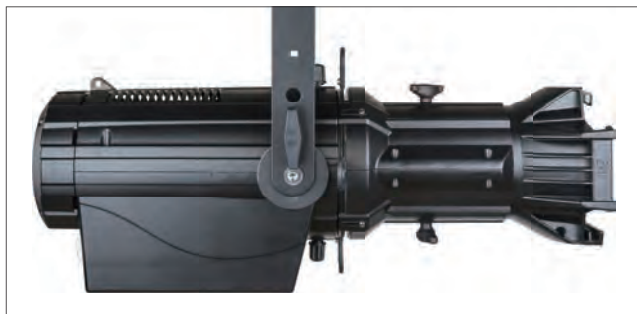

The housing is fabricated of aluminum alloy; lightweight, durable, and excellent for heat ventilation.



Superior optics and powerful COB light engine gives a great amount of light output. Available in 19o, 26o, 36o, 50o lens tube, and standard ETC accessories is applicable.



Rear LCD control panel is convenient for navigating the setting. Power and signal in/out receptacles are integrated making the control easier. Great performance with linear dimming 0-100%.



Fabricated with motorized optical design, this luminaire makes the beam adjustment smoothly and precisely. It is built up with 200W COB LED in two versions, RGBW or bi-color whites for tuning 2700K to 5600K color temperature in between, to fulfill the need of versatile effects. The LED has a lifespan exceeding 50,000 hours.



Specification

- Power Input: AC100-240V, 50/60Hz
- Power Consumption: 250W
- LED Source: COB LED 200W
- Control: on/off, or DMX-512
- Luminous Flux: 23800-26000lm
- Beam Angle: 15° ~55°
- Color Temperature: Tunable white 2700-6500K, 3200K/5600K or RGBW
- CRI: ≥ 90Ra
- DMX inlet/outlet: on-board 3pin and 5pin XLR
- Power inlet/outlet: PowerCon compatible connector
- Protection grade: IP20
- Working environment: -20°C ~ 45°C
- N.W.: 8.4kg
- G.W: 10.8kg
- Dimension: 520(L) x 315 (W) x 320(H)/mm
- Please specify 3pin or 5pin XLR connector while making order.
- For **5600K daylight** / **RGBW** version, the item number will come with **D** / **C** in the suffix.

ZFS-M250T Motorized LED Fresnel
250W LED Motorized Fresnel Light, Tunable White 2700-6500k
(4 or 5 DMX Channels)

ZFS-M250DC Motorized LED Fresnel
250W, 3200K/ 5600K/ RGBW
(2/3, **D** DMX Channels)

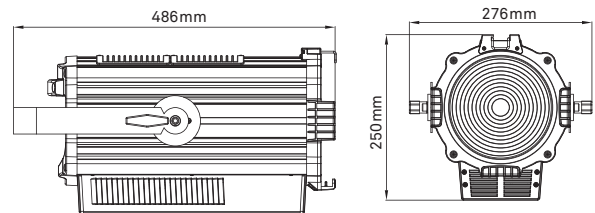

Photometric for ZFS-M250T

Beam Angle	Throw Distance (M)	1M	2M	3M	4M	5M	6M	7M	8M
15 degree	Illuminance (Lux)	64160	19560	9296	5471	3609	2441	1859	1426
45 degree	Illuminance (Lux)	21860	6401	2912	1737	1128	803	613	474



LCD screen display makes setting navigation easier. Convenient DMX signal linkup with 3pin or 5pin XLR. Power in/out receptacles for handy operation.



Extruded aluminum housing with ventilation holes for better heat control. Built in heat-sink and the fan helps to regulate the working temperature more efficiently.



Beam adjustment, from 15 to 55 angle degrees, is achieved by motorized zoom in/out button or through DMX-512 signal.



4-leave barndoor is supplied as standard accessory for lighting control.

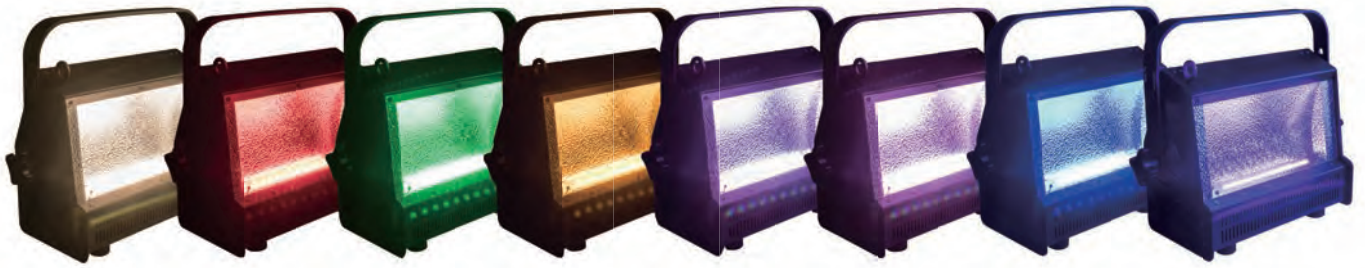

The Cycloramas equipped with an asymmetric optical system and diffusers offer a distinct advantage over spotlights. They are specifically designed to efficiently illuminate expansive surfaces, like theatrical backdrops, by providing the widest and most uniform light beam possible (V90°/H120°). Therefore, the space in between allows for the installation of additional lights without requiring a dedicated truss or suspension pipe solely for the Cycloramas Lights — This setup ensures a quick, flexible, and versatile installation process.

KUPO LED cyclorama delivers pure and even color wash with powerful light outputs. The 150W and 200W luminaires are fabricated of aluminum alloy housing, making it lightweight yet rigid. Similar to classic Par Can, this cyclorama is made with big lock washers providing positive firm lock while rigging with the bracket. The asymmetric anodized aluminum reflector delivers wide and even light distribution. Available with three visible light models, RGBA, warm white, tunable white (warm white + cool white) and also invisible light source UVLED for special effect in theme park.



Yoke lock washer provides positive locking; ventilation slot makes the better controls of working temperature.



Anodized asymmetric aluminum reflector gives the light output distribution even and smooth. Large solid bracket provides durable and robust rigging support for the luminaire. An eye ring is equipped for attaching the safety bond.



LED light source consists of high quality LED engine, available with RGBA, 3200K warm white, tunable white (3200K warm white+6000K cool white), and UV LED at 365nm.



On-board LCD screen clearly displays the function and all settings through push buttons. DMX controllable through 3pin or 5pin XLR outlets.



UV LED Cyclorama Application



Rubber footpad for stabilizing the luminaire while it is upright on the ground.

Features

1. Full DMX-512 controllable.
2. Universal Power Input: AC/100-240V, 50/60Hz.
3. Both power and signal feed through for daisy chain.
4. Asymmetric aluminum reflector.
5. Yoke lock washer and solid large bracket for positive lock; eye ring for safety bonding.
6. Available with RGBA, 3200K Warm White, Tunable White (3200K-6000K) and UV LED.
7. Rubber footpad protects the housing from scratch in upright position.
8. Functions (for RGBA mode): Color mixing, automatic color change, built-in program and strobe effect with adjustable speed, dimmer, master / slave.



ZLC-150RGBA LED Cyclorama

150w RGBA LED Cyclorama

ZLC-150WW LED Cyclorama

150w 3200k Warm White LED Cyclorama

ZLC-150TW LED Cyclorama

150w 3200k-6000k Tunable White LED Cyclorama

ZLC-150UV LED Cyclorama

150w UV LED Cyclorama

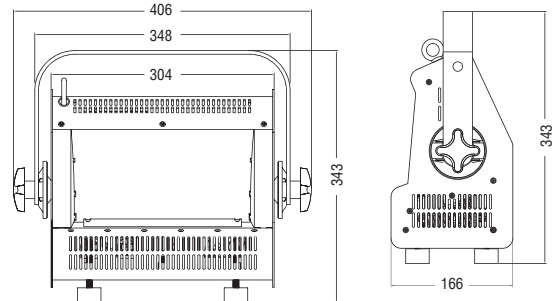

Specification

Voltage: AC/100-240V, 50/60Hz

Power Consumption: Max. 150W

Light Source:

48 x 3W RGBA LEDs

48 x 3W Warm White LEDs (3200K)

24 x 3W Warm White (3200K) + 24 x Cool White(6000K) LEDs

48 x 3W 365nm UV LEDs

Signal Connector: 3pin and 5pin XLR

Working Mode:

DMX-512, Max 16 channels

Stand-alone built-in program

Strobe effect

Dimmer 0-100%, fade effect

Master-Slave mode

Protection Classification: IP20

Dimension: 406 x 166 x 343mm

Weight: 5.7kgs



ZLC-200RGBA LED Cyclorama

200w RGBA LED Cyclorama

ZLC-200WW LED Cyclorama

200w 3200k Warm White LED Cyclorama

ZLC-200TW LED Cyclorama

200w 3200k-6000k Tunable White LED Cyclorama

ZLC-200UV LED Cyclorama

200w UV LED Cyclorama

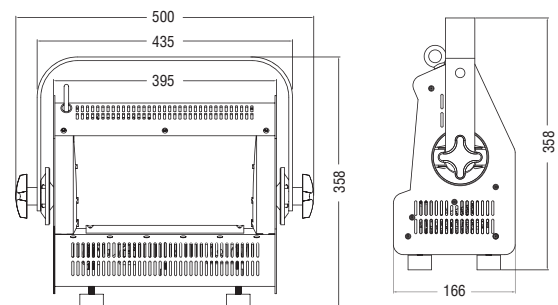

Specification

Voltage: AC/100-240V, 50/60Hz

Power Consumption: Max. 200W

Light Source:

72 x 3W RGBA LEDs

72 x 3W Warm White LEDs (3200K)

36 x 3W Warm White (3200K) + 36 x Cool White(6000K) LEDs

72 x 3W 365nm UV LEDs

Signal Connector: 3pin and 5pin XLR

Working Mode:

DMX-512, Max 16 channels

Stand-alone built-in program

Strobe effect

Dimmer 0-100%, fade effect

Master-Slave mode

Protection Classification: IP20

Dimension: 500 x 166 x 358mm

Weight: 8.0kgs

This 180W Outdoor PAR LED luminaire is made of die-cast aluminum alloy. Sturdy and robust. IP65 rated for short-run or permanent installation surrounding with moisture. The housing is made with grooves, offering better heat ventilation. Standing on the ground or rigging on the truss can be easily convertible with two supportive brackets. Power and DMX-512 signal lead are pre-wired with water-proof connectors, for making feed-through conveniently. Function setting panel and display screen are well protected against the water ingress for maximum service life.



ZPW-64 / 18-10 Outdoor LED Par
180w RGBW LED Outdoor Par

Features

1. Functions: Color mixing, built-in program and strobe effect, dimming, master/slave.
2. 0-100% linear dimming.
3. Power & signal feed through with IP65 connectors.
4. Fully comply with DMX-512 protocol.
5. 4-digit LED setting menu with function buttons.
6. IP65 protection classified for outdoor application.

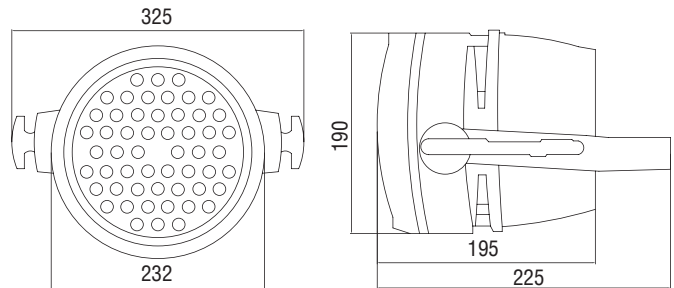

Grooved aluminum die-cast housing features lightweight and toughness, and great with heat ventilation. Two full-size brackets give strong rigging support.



Function setting and display screen are insulated against the moisture and dust for the maximum durability.



Power and signal leads are pre-assembled with watertight metal cable gland. Cables are over-molded with IP65 connectors to make the power and DMX-512 signal feed through without moisture issue.

Specification

Voltage: AC/100-240V, 50/60Hz
Power Consumption: Max. 180W
Light Source: 18 x 10W RGBW LEDs
Signal Connector: 3pin water-proof XLR
Protection Classification: IP65
Weight: 5.5kgs

Working Mode:
DMX-512, Max 7 channels
Stand-alone built-in program
Strobe effect
Dimmer 0-100%, fade effect
Master-Slave mode
Dimension: 280 x 290 x 290mm



LED PAR CAN renders vivid and colorful changing effect in the stage. Kupo's LED PAR is build up with PAR-64 sturdy textile of barrel and equipped with high power RGB LED, making it the ideal choice and catering to the entertainment requirement. Standard finish is black white or other color is available for special request. In addition to the version with RGB color mixing, fixed color LED PAR CAN including 3,200K warm white and 6,200K cool white are also available. An unique design on daisy chain power is set to offer simple and convenient access to the electricity; up to 10 units of LED PAR can be put together for power linkup.



for sound active effect.



Fixed spring set.



Heat sink for better ventilation.

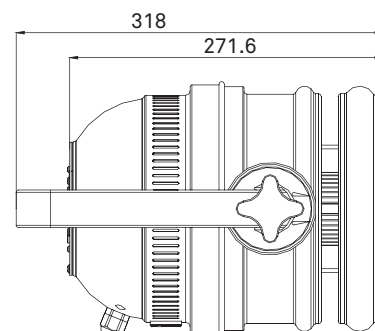
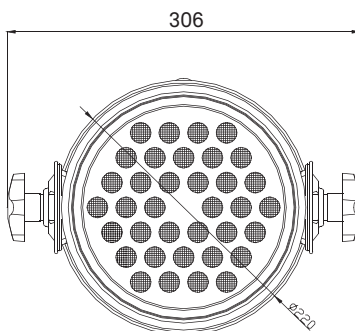

ZPL-64 / 36-5 LED Par Can

Voltage: AC 100-240V/ 50-60 Hz
 Power Consumption: 180W
 LED Unit: 36pcs * 5W LEDs
 Beam Angle: 25 / 45 degree optional
 DMX Channel: 5 & 6 channels
 Control: DMX 512 / Master & Slave
 Effect: RGB mixed color, dimming mode, flash, color changing, color fading and sound active
 Working Environment: Indoor -20~50 degree C
 Net Weight: 2.95 kg

ZPL-64 / 36-3 LED Par Can

Voltage: AC 100-240V/50-60Hz
 Power Consumption: 120W
 LED Unit: 36 pcs*3W LEDs (RED 12pcs/ Green 12pcs/ Blue 12 pcs)
 Beam Angle: 10 / 25 / 45 / 60 degree optional
 DMX Channel: 5 & 6 channels
 Control: DMX 512 / Master & Slave
 Effect: RGB mixed color, dimming mode, flash, color changing, color fading and sound active
 Working Environment: Indoor -20~50 degree C
 Net Weight: 2.95 kg



ZPL-64 / 18-10 LED Par Can

Voltage: AC / 100-240 V, 50 / 60 Hz
 Power Consumption: 180 W
 LED Unit: RGBW, 18 x 10 W (4-in-one), 3200 K or 6500 K (white)
 Beam Angle: 25 / 45 degree optional
 DMX Channel: 1-7, 16 channels
 Control: DMX 512, Master / Slave
 Effect: Color mixing, dimming mode, fading, sound active
 Working Environment: Indoor -20~50 degree C
 Net Weight: 2.9 kg

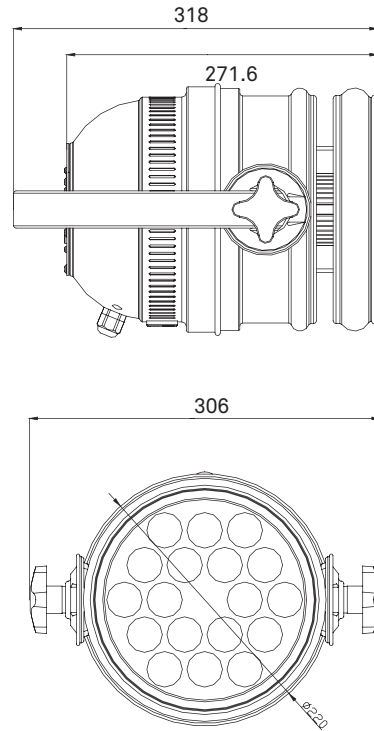

LED PAR-56 is built of classic robust aluminum PAR-56 barrel and equipped with high power RGB or white LED, making it the ideal luminaire when the splendid color mixing effect is required. The unique power daisy linking helps to offer quick access to electricity and makes cable management easier. Available in black or white housing and other finish is available in request.

Specification

LED: 36pcs x 3W LEDs (RGB or white)
 Power Consumption: 120W
 Beam Angle: 10°/25°/45°/60° optional
 DMX Channels: 1-6 channels
 N.W. (kgs): 2.5 kgs

Voltage: AC 100-240V, 50-60Hz
 Control: DMX512, Master / Slave
 Effect: RGB mixed color, dimming mode, flash, color changing, color fading, sound active.
 Environment: -20°C ~50°C



ZPL-56 LED Par-56

108W RGB Led Par-56 (Black Finish)

ZPL-56W LED Par-56

108W RGB Led Par-56 (White Finish)

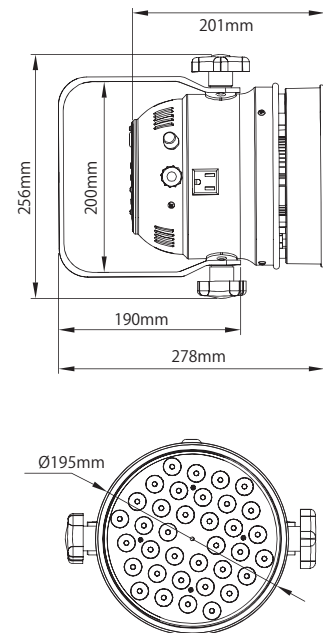

Built of sturdy die-casted aluminum housing and high power COB LED module, LED MegaPar delivers outstanding performance with excellent color changing effects. Each 20W COB RGB LED module generates the most abundant color mixing hue, and then casts the powerful lighting through 30 degree optical reflector. Diverse lighting effects leaves the versatile applications easy. Universal power input and signal daisy chain makes the job quick and simple.

Specification

Voltage: AC/100-240V, 50/60Hz
 Power Consumption: 80W
 Beam Angle: Lens 30 degree
 Light Source: 4 x 20W 3-in-1 RGB COB LED
 Connectors: 20A Powerlead in & out + 3pin XLR in & out
 Setting Display: LCD Screen
 Environment: -20°C to 40°C

IP Rating: IP20
 DMX Channel: 1, 2, 7, 11, 12 & 25 Channels
 Control: DMX-512
 N.W. 4.2 kgs
 Effect: 20 built-on programs / Dimming 0-100% Fade effect
 Strobe effect / Sound active effect / Master / Slave

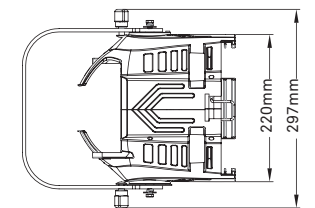
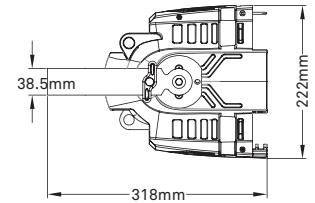

ZMP-080 LED Mega Par

80W, Led Mega Par, 4 X 20W COB RGB

A compact version of LED Megapar, these mini LED luminaires are built of die-casted aluminum case featuring sturdy yet lightweight. As of the same profile and dimensions, LED Mini MegaPar brings three selections with different light outputs for diverse applications. LED color mixing delivers the space with vivid light effect and vibrant atmosphere. Universal power input and signal daisy chain makes the job quick and easy.

Specification

- Environment: -20°C to 40°C
- Power Cable: H05VV-F, 3 x .75mmsq, Length 1M
- Setting Display: LCD Screen
- IP Rating: IP20
- DMX Channel: Up to 16 channels
- Control: DMX-512
- Effect: 10 built-on programs
- N.W.: 2.1 kgs
- Dimming 0-100% Fade effect

- Strobe effect
- Sound active effect
- Master / Slave

Features

1. High power 4-in-1 or 5-in-1 LED.
2. Compact and lightweight aluminum die-casted housing.
3. Signal daisy link for easy operation.
4. Up to 16 channels for color mixing and working selections.

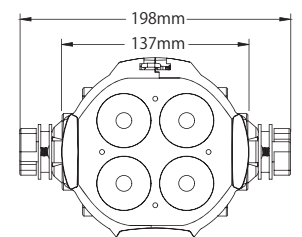
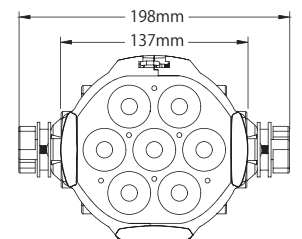
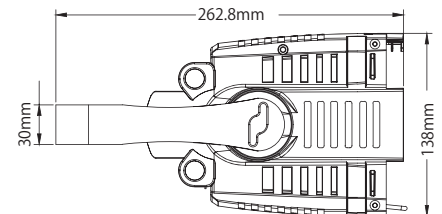

ZMP-028 LED Mini Mega Par

Voltage: AC/100-240V
 Power Consumption: 28W
 Beam Angle: 25 / 45 / 60 degree
 Light Source: 7 x 4W RGBW (4-in-1)

ZMP-040 LED Mini Mega Par

Voltage: 50/60Hz
 Power Consumption: 40W
 Beam Angle: 15 degree
 Light Source: 4 x 10W RGBWA (5-in-1)

This 200W LED zoom profile is made of extruded and metal sheet aluminum alloy featuring lightweight yet sturdy. Equipped with two aspheric Fresnel lens for 17° - 55° beam angle adjustment. A diverse line of COB LED choices are available including RGBW, 3200K warm white and tunable white (3200K+5600K) It is designed and fabricated for the efficiency and operation convenience in the event and theatrical performance.

Specification

- Voltage: AC/100-240V, 50/60Hz
- Power Consumption: 200W
- Beam Angle: 17 to 55 degree
- Light Source: RGBW (4-in-1) COB / 3200K warm white COB / Tunable white (3200K + 5600K) COB
- Connectors: 20A Powerlead in & out + 5pin and 3pin XLR in & out
- Setting Display: LCD Screen
- Environment: -20°C to 40°C
- IP Rating: IP20
- DMX Channel: Up to 16 channels
- Control: DMX-512
- N.W.: 8.5 kgs

- Effect: 20 built-on programs / Dimming 0-100% Fade effect / Strobe effect / Sound active effect / Master&Slave

Features

1. 3200K warm white CRI > 90 for great performance.
2. Polycarbonate Fresnel lens provides smooth and even light output.
3. Accessory slots accommodate iris, metal or glass pattern holder.
4. User-friendly rear control panel integrated with on-board DMX address setting and LCD screen.
5. Built in both 5pin and 3pin XLR for the convenience of signal transmission.



ZML-Z1755A LED Zoom Profile

200W LED Zoom Profile, 17-55 degree, RGBW

ZML-Z1755B LED Zoom Profile

200W LED Zoom Profile, 17-55 degree, 3200K warm white

ZML-Z1755C LED Zoom Profile

200W LED Zoom Profile, 17-55 degree, tunable white (3200K + 5600K)



User-friendly interface for user's setting.



Ventilation slot for better heat management.



Accessory slot fits 18-leave or 24-leave Iris.



Accessory slot is suitable for pattern or glass gobo holder.

Knobs provide lens zoom adjustment for 17°-55° beam angle.

Kupo 500W LED event spot is fabricated with aluminum alloy housing, lightweight and durable. Made of 12 units of 40W high power and high CRI white LED light engine, this event spot provides as much as 34700 lumen at 5 meters projected distance with pure and great quality of light. Cooling system, integrated with heat sink, copper heat pipe and quiet fan, provides the excellent thermal control of the luminaire for making the life span longer. Suitable for exhibition and conference venues where constant and powerful white light is required.

Features

- All aluminum chassis and bracket; lightweight, durable and rusty-free.
- White LED with high fidelity CRI(Ra>90); making the more accurate the white LED color will be.
- Luminaire generates 34700 lumens with 8 degree beam angle at 5 meter projected distance, very powerful and brilliant performance.
- Superior thermal management; while working temperature rises up to 75 degree Celsius, fan will switch to full speed to cool down the heat, making the LED longer life span exceeding 30,000 hours.

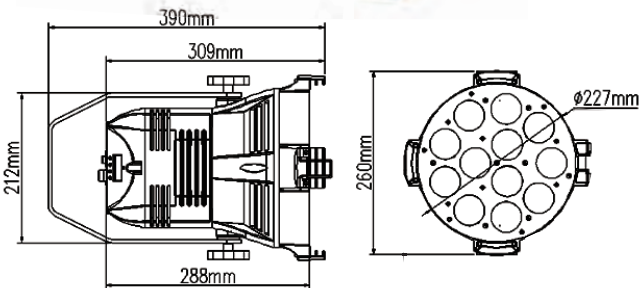

ES-LED500D LED Event Spot 500

Specification

- Voltage: AC100V-240V, 50/60HZ
- Power Consumption: 500W
- Light Source: 40W x 12pcs white LED
- Color Temperature: 7000-7500K
- Color Rendering Index: Ra>90
- Beam Angle: 8° or 13° lens option
- Optional Accessory: 30° diffuser
- LED Life Span: 30000 hours
- Luminous Flux: 24000 lumen
- Dimming: 0-100%
- Special Effect: Strobe (frequency adjustable from slow to fast)
- Control Protocol: DMX-512
- Control Channel: two channels (intensity, strobe)
- Protection Class: IP20
- CE Compliance
- Working Environment: 0-45°
- Net Weight: 6.6kg



12 unit of 40W high-power white LED with 8° narrow beam lens gives the greatest light output.



Die-cast Aluminum housing makes the luminaire lightweight yet robust. U-type bracket facilitates flexible mounting adjustment.



Great cooling is derived from numerous ventilation slots on the housing and ultra-quiet fan built inside. Fan speed is adjustable via DMX control.



Rear panel finds the LED display, on/off switch, setting button, protection fuse, and power/data connection ports; convenient and easy to operate.

Optical Illuminance

Distance	5M	6M	7M	8M	9M	10M	11M	12M	13M	14M	15M
8 Degree / Illuminance (Lux)	34700	24500	18300	14200	11100	8930	7410	6130	5280	4420	3670
13 Degree / Illuminance (Lux)	21200	14400	10800	8090	6560	5160	4380	3590	3130	2760	2410
30 Degree / Illuminance (Lux)	3600	2520	1900	1430	1130	896					

Inherited with the profiles of classic HMI 575 Event Spot, the new LED Event Spot features energy-saving advantaged and made with 37pcs superior high power LED with custom-fit lens to produce as 8000 (LUX) great intense light as astonishing and incomparable high output (measured in white LED at 7 meter ahead of fixture without diffuser). Ventilation holes are deployed around the back housing for better management of working temperature so as to prolong the life span of LED. Excellent mechanical fabrication, such as die-cast spring gel clip, double positive locking knobs and robust U bracket enhances the durability. Universal power input is global-fit no matter where the event takes place.

1. Fabricated of aluminum alloy, lightweight and good for heat dissipation.
2. CREE high-power white LED ensures the most stable and outstanding performance.
3. Dimmable through DMX-512 control; 3pin XLR in & out for the convenience of multiple link.

Specification

- Light Source: 37pcs x 10W CREE white LED.
- Color Rendering Index (CRI): 70 (standard), or 90 (optional).
- Color Temperature: 6500K (standard), or 3000/5600/7000 (optional).
- Illuminance: 8000 Lux (at 7 meter)
- Luminous Flux: >40700 Lumen
- Power Consumption: 300W
- Input Voltage: AC/100-240V, 47-63Hz
- Power Factor: ≥ 0.95
- Net Weight: 5.5kg



37 x 10W CREE high-power white color LED, with color rendering index 70 (or 90), provides the greatest light output.

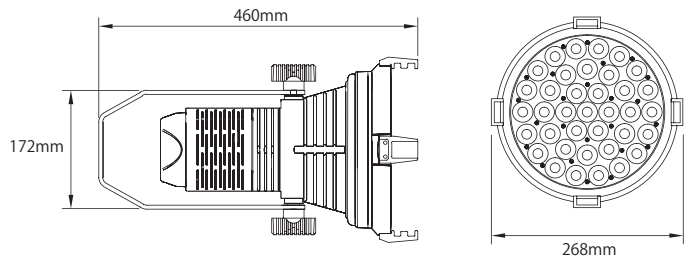

ES-LED300FD LED Event Spot

37pcs High-Power LED Event Spot, 300W, CRI 70, 6500K White LED (Other requests specify by order)

BDR-300FD LED Event Spot

Barndoor for ES-LED300FD

SW-300FD LED Event Spot

Safety wire for ES-LED300FD



Aluminum alloy chassis and ventilation slots helps to maintain longer LED lifespan.



Hanging bracket is equipped with double ratchet handles for firmly positive lock; M12 fixing hole in the central for attaching lighting clamp.



Connection and control settings are all deployed at the rear panel. Clear and easy to manipulate. Standard comes with lead wire. Optional with PowerCon compatible connector.



Optional

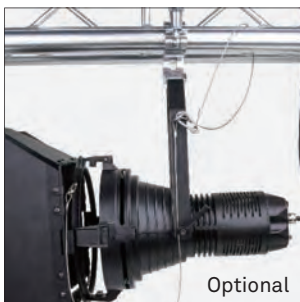

Customized safety wire (optional) is bolted on the yoke and comes with two cables for securing barndoor and the light with truss.



Durable and sturdy aluminum die-cast spring clip for securing barndoor attachment.



4-way barndoor helps to shape the beam of the light and prevent light spilling.



Optional

Three diffusers (optional) with frame soften light beam and produce wider projected field. Available with soft tune, wide flood, and CTO (from 6500K to 3200K).

Color the vivid and vibrant atmosphere to the show or venue. LED pixel strip is made of aluminum extruded body, making it extremely compact, lightweight and good heat dissipation. Ultra slim profile has it fashionable and suitable for wide applications such as decorative and accent lighting applications. Come with mounting bracket for easy installation.

Features

- 40pcs individual addressable RGB SMD LED creates astonishing color changing effect.
- Only 37mm width, ultra-thin and neat profile, required less space to install.
- Quick and simple installation; no cumbersome tool needed.
- LED pixel strip can easily link up to each other via RJ45 connector; max. 4 units of LED pixel strip can be put together in one string.

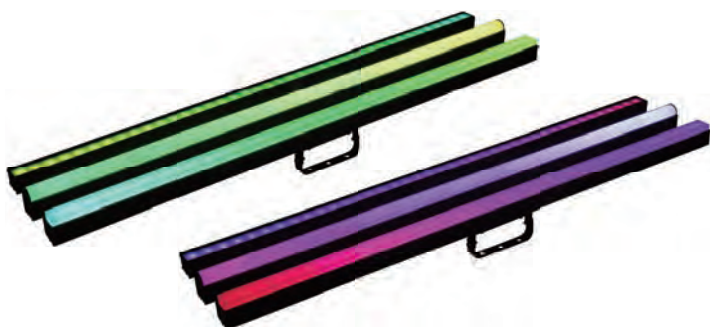

Three diffusers available for LED pixel strip



120 degree frosted flat cover

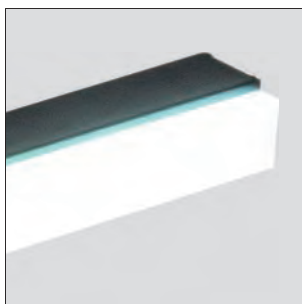

120 degree milky white rectangular cover



180 degree milky white semi-sphere cover



LED Pixel Strip Specification

Power Consumption: 12W
 LED Source: 40pcs SMD 5050 RGB LED, spacing P25mm
 LED diffuser degree: 120 degree, or 180 degree
 DMX channel: 120 channels per each pixel light
 Brightness: 828 nits (with frosted lens)
 Protection grade: IP20
 Working environment: -20°C ~ 45°C
 N.W.: 2.0kg

Dimension:

1000(L) x 37(W) x 40(H)/mm (ZPX-1201)
 1000(L) x 37(W) x 50(H)/mm (ZPX-1202)
 1000(L) x 37(W) x 55(H)/mm (ZPX-1203)

LED pixel strip controller is not only working with DMX-512, but also Art-net and Kling-net or lighting control software, such as Madrix, to program the lighting effect from computer. Connecting DMX signal via 3-pin XLR, or Art-net or Kling-net via LAN port. Four outlets provides power and data for LED pixel strips.



Front View



Rear View



M10 threaded hole for attaching the controller with lighting clamp to rig on the truss.

Controller Specification

Power Input: AC100 or 240V (switchable), 50/60Hz
 Power Connector: 20A in/out PowerCon compatible connector
 Power Consumption: 300W
 Date Connections: RJ45 for Kling-net & Art-net, and DMX-512
 Connection: 4 ports for connecting pixel light, each port supports 4 units of pixel lights
 Control model: Stand-alone, DMX-512 (3-pin XLR), Art-Net (LAN), Kling-net (LAN)
 N.W.: 2.0kg
 Dimension: 204 (L) x 260(W) x 88(H)/mm

ZPX-1201 LED Pixel Strip

12W LED pixel strip, 120 degree frosted flat cover.

ZPX-1202 LED Pixel Strip

12W LED pixel strip, 120 degree milky white rectangular cover.

ZPX-1203 LED Pixel Strip

12W LED pixel strip, 180 degree milky white semi-sphere cover.

ZPX-C01 LED Pixel Strip Controller

Controller for LED pixel strip

Tungsten Junior caters to lots of requirement for 3200K warm tone. The luminaires are built up with sophisticated low expansion borosilicate Fresnel lens and fine anodized reflector to create perfect soft note and evenly-distributed light field. Constructed of high tensile aluminum alloy, the housing is light weight, compact, rust-free, sturdy as well as perfect for heat ventilation. Tool-free top opening (or front opening in some models) chassis facilitates lamp change quickly within seconds. Through rotating and heat-resistance focus adjustment knob, wide field or focus beam effect can be managed easily. Sturdy in-line on / off switch is equipped in all models for handy operation. Rigid barndoor and stainless steel round-shape gel frame is supplied as durable as the complete fixture.

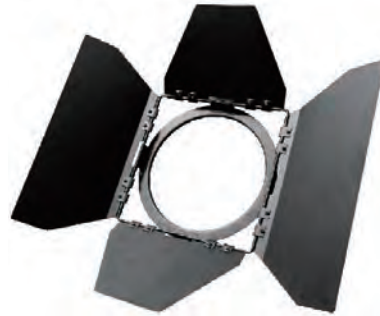

Tungsten Junior

Accessories

Aluminum 4-leaf barndoor and stainless steel color frame comes standard.

Model	LSW-010	LSW-001	LSW-002	LSW-003	LSW-004
Watt	150W	300W	650W	1000W	2000W
Lamp/Base	GX6.35	CP81/GY9.5	CP89/GY9.5	CP40/G22	CP73/G38
Dimension (mm)	165(L) x 146(W) x 205(H)	175(L) x 220(W) x 260(H)	195(L) x 225(W) x 325(H)	270(L) x 260(W) x 373(H)	306(L) x 362(W) x 562(H)
Net Weight (kg)	1.2	2.1	2.5	5.3	9.0
Lens Diameter (mm)	50	80	112	130	175
Barndoor (mm)	78	128	162	194	245
Filter Frame (mm)	75	130	170	192	230
Supplied Connection	16mm receiver	16mm receiver	16mm receiver	16mm receiver	28mm spigot



Color frame clip and front chassis are both spring-loaded; press to open and make the maintenance easy and tool free.



Rear and front focal adjustment knobs are made from heat-resistant thermoplastic for comfort operation. This fixture comes with 3M / 3C x 2.5 mmsq power cable.



Spiral cable gland stops power cord from over bending; cable comes less stressful as it is in line with the direction of fixture while tilting down.



Ratcheted handle, coming with large disk brake, for positive and effortless locking.



Cable strap is supplied to all models providing excellent cable management; in-line on/off switch is equipped for conveniently near field control.

Megalite is known for its outstanding characters and excellent craftsmanship. It is made in black with non-reflective matt painting for less visibility where any glittering is strictly controlled. Ideal for not only the theatre but also for the venues where precise light control is required.

Features

1. Die-cast aluminum alloy housing, featuring sturdy and robust and handling great ventilation for such compact fixture with high light output, leaves it the best choice for installation and rigorous touring environment.
2. Plastic parts on the fixtures are made of heat-resistant thermoplastic for best insulation, providing the durability and safe operation.
3. Sophisticated dichroic-coated glass reflector transmits the IR heat to the back side, and produces cooler visible light forward.
4. Front aspherical lens efficiently eliminates the distortion on the rim of output image and ensures fidelity.
5. Resilient stainless-steel shutter operates handy beam-shaping and free from deformation with working heat.
6. Tool-free lamp housing attachment facilitates the quick lamp changing .
7. The series is available in 19, 26, 36 and 50 degree with interchangeable lens tube design.
8. Gobos, Iris, Top hat and other light control accessories are dimensionally compatible with the major brand.
9. All fixtures are equipped with 100 cm 3C x 1.5 mmsq silicon rubber cable.

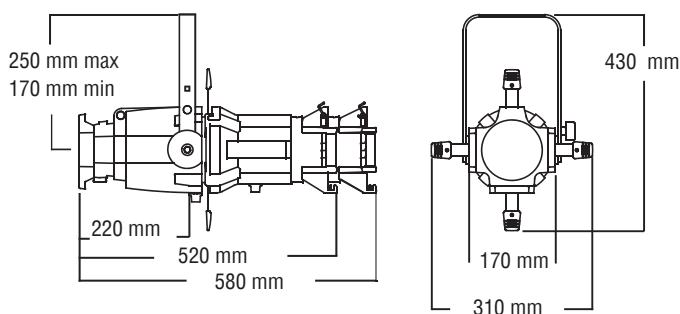

ML-7519B Megalite

Megalite with 19 degree lens tube, Black

ML-7526B Megalite

Megalite with 26 degree lens tube, Black

ML-7536B Megalite

Megalite with 36 degree lens tube, Black

ML-7550B Megalite

Megalite with 50 degree lens tube, Black



Rugged shutters, made of resilient stainless steel, ensure deformation proof with either 575 or 750W lamp in operation; slot for seating Iris, pattern holder and other great accessories.



Locking knob, fabricated with heat-resistant thermoplastic, together with large disc for firmly positioning.



Aspherical lens on the front tube authentically produces great image contrast and eliminates the distortion; spring clip facilitates accessories attachment easily.



Focal adjustment or interchangeable lens tube is just as simple with a knob beneath the lens tube.

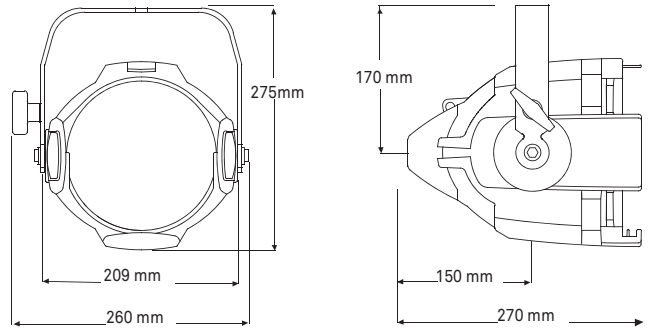

MP-575B Megapar
MM-575B Megamix

Silver-gray or white is available upon request.

Enhanced aluminum reflector is made of die-casting with aluminum sputtering for greatest light projection; fin construction provides superior heat convection.



MP-150EB Megapar CDM 150W

Made of classic model, Megapar CDM has extended-profile of yoke that offers more space to seat a side-mounted ballast chassis, which is also made of the same craftsmanship as main housing, ensuring the best heat ventilation to cool down working temperature generated by ballast. Ballast compartment space is designed for PHILIPS HID-PrimaVision electronic ballast, and also feasible to the other brands.

The classic and functional form of ParCans have been established in the Rock'n Roll world. Kupo ParCan is manufactured from high quality spun aluminum for maximum durability. Black and silver are standard colors, and other colors are available when specify on the order.

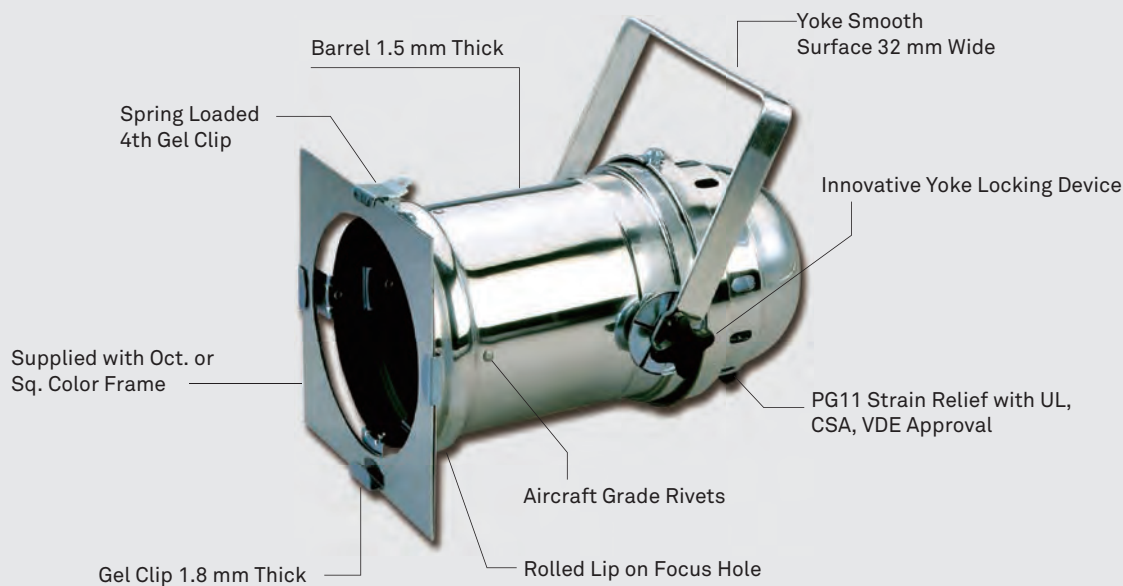

Par 64/56 is manufactured by using GX-16D base lamp holder for mains voltage lamps up to 500 watts (PAR56)/1000watts (PAR64). It is fitted with a color frame as standard. Each unit comes with a 72 cm silicon cable. Available with long nose or short nose, black or polish, floor type or customized configuration. UL version is also available.



Par 64 Long Nose

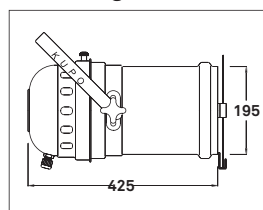

Par 56 Long Nose

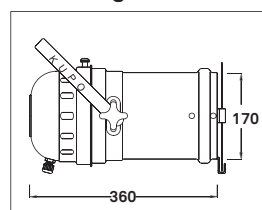

Par 64 Short Nose

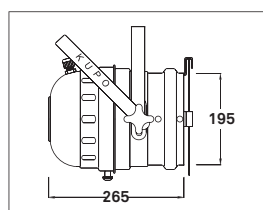

Par 56 Short Nose

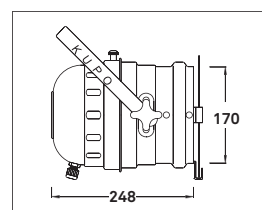

Par 38 lanterns are manufactured with E27 base and 50cm 3 x 0.75mmsq silicon cable, and coming with square color frame. The standard Par 46/36 comes without lampholder and cable unless you specify when place the order. It is fitted with a color frame as standard. Optional with E27 base and silicon cable.



Par 46 Long Nose

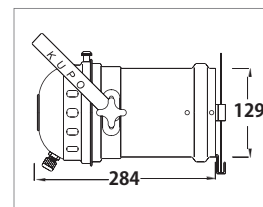

Par 36 Long Nose

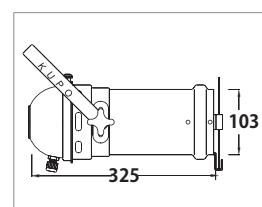

Par 46 Short Nose

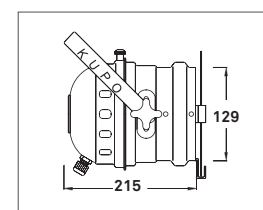

Par 36 Short Nose

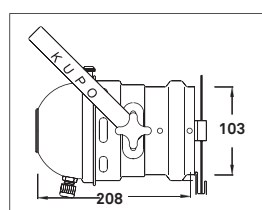

Par 38 Short Nose

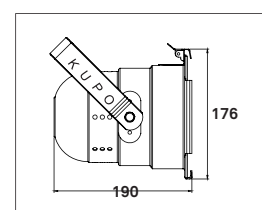

Par 30 and 20 are manufactured by using E27 or medium base lampholder for mains voltage lamps up to 150 watts. Par 16 lantern is suitable for use with MR16 range of 12 volt lamps and GZ10 range of 230V lamps. Par 11 is a short nose lantern using E11 socket with color frame but lamp and transformer are not supplied.



Par 30 Long Nose

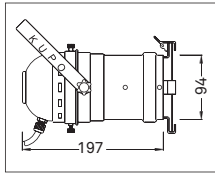

Par 20 Long Nose

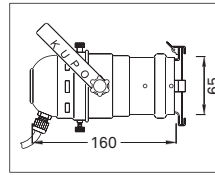

Par 16 Long Nose

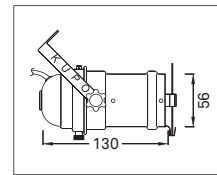

Par 20 Short Nose

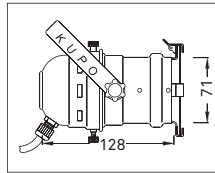

Par 16 Short Nose

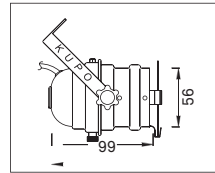

Par 11 Short Nose

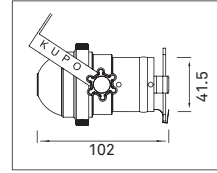

4-Leaf Barndoor for ParCan

Lightweight, compact size, foldable blade & adjustable direction four-leaf barndoor available for whole ParCan series. Standard is black finish. Other finishes are available. * Prior to purchasing barndoor, please notice the discrepancy as ParCan dimension might vary by different supplies.

BDR-56B

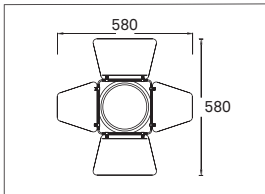

BDR-46B

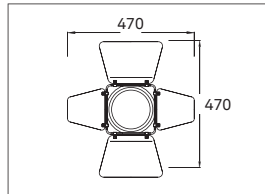

BDR-30B

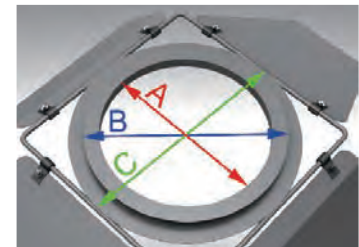
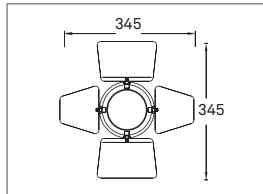

BDR-20B

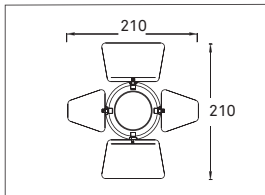

BDR-36B

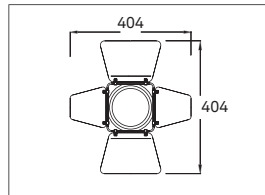

BDR-16B

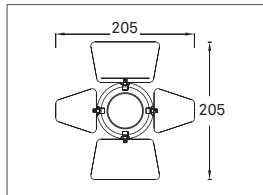

BDR-64B

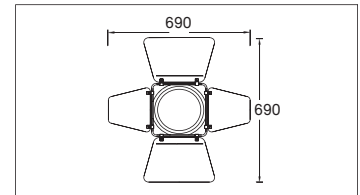

ITEM Ø (mm)	A	B	C
BDR64	218	239	262
BDR56	188	210	228
BDR46	152	174	186
BDR36	121	142	169

ITEM Ø (mm)	A	B	C
BDR30	100	127	143
BDR20	56	79	88
BDR16	51	73	83



ADJ-64 Adjuster for PAR64 & PAR56

Socket for Par 64 / 56



ES-01 EMEP socket



ES-02 Top Off Ceramic Socket



PS-64 Parsafe for Par 64 / 56

It is with high temperature resistance, which offers great benefits to can.

1. Provide safe operation when lamp is installed
2. Double electric insulation (excluding socket)



ES-01SC EMEP Socket with 72cm Silicon Cable

Kupo CYC & FDL are made with high standards. The following demonstrates the features of the range.



Gel frame with cutting teeth.

High tensile Extruded aluminum rear housing.

Metal case protected by a coat of heat and scratch-resistant matt black epoxy powder paint.

Body section are ribbed for greater strength and to maximum the cooling surfaces.

Lightweight, rugged diecast aluminum side panels, with safety wire location point.

Rigid ceramic R7S lamp base.

Side panel fittings allow interlocking side by side for groundrow application.

Anodized aluminum reflector.

5.0mm safety glass.

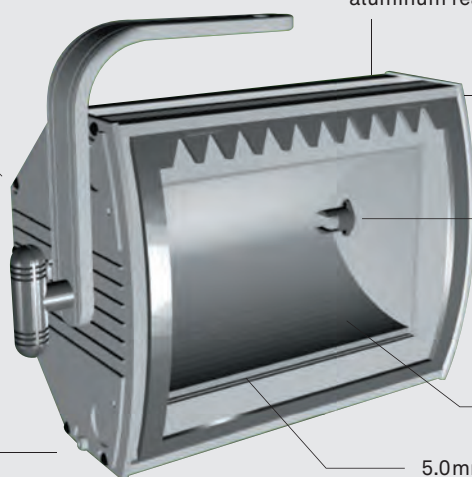

Fixture quickly and securely interlock side by side for ground row application.



Ground row joint



Easy and safe lamp installation is provided via a hinged access door. Friendly and easy gel installation is supported with the hinged access door designed on color frame. The gel can be settled smoothly without wrinkle.



microswitch

TUV Version composes the microswitch. When door is opened power of lamp housing is automatically shut off.



Excellent ventilation is provided with air circulation paths at both rear and front of the reflector/ lamp housing.



CYC-500

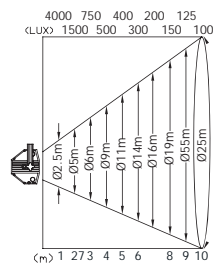
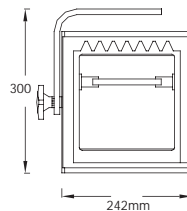
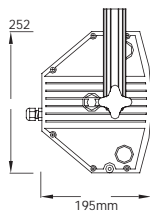

CYC-1000

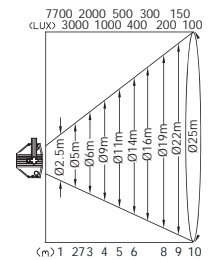
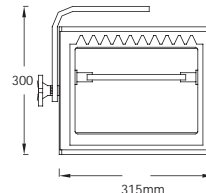
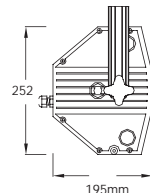

CYC-500 / 1000



FDL-500

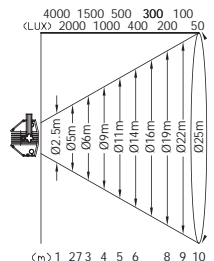
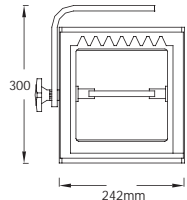
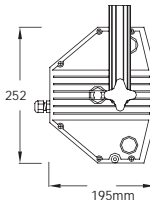

FDL-1000

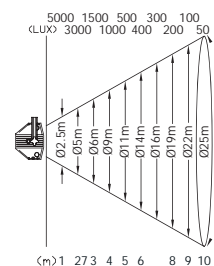
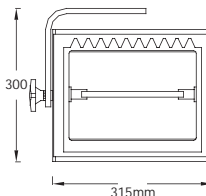
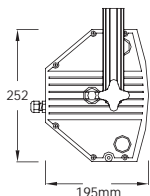

FDL- 500 / 1000



BDR-500

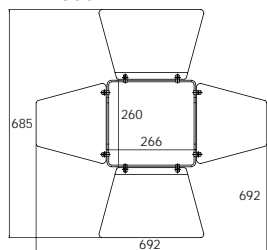

BDR-1000

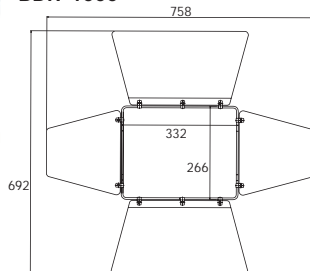

BDR-500 Barndoor (BDR)

BDR-1000 Barndoor (BDR)



R7S

Socket for CYC & FDL
Dia. 1.5 mmsq Length 25 cm.



LAMP for CYC & FDL

J-type 500W, length 119.1mm
J-type 1000W, length 189.1mm



YL-1500 Flexible linking Yoke for CYC / FDL

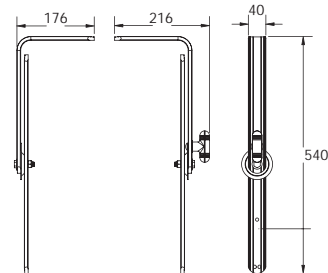

These two luminaires are most often used in the theatre for top or back lighting at medium throw distance. Kupo Fresnel and Prism Convex are well-known for its classic design and built with aluminum alloy, making the lighting lightweight and sturdy for theatre.

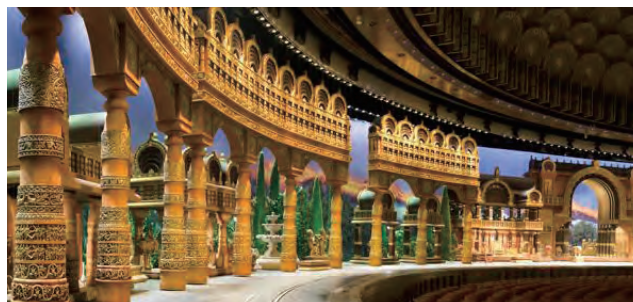

Ribbed body and meshed top plate for better cooling convection.

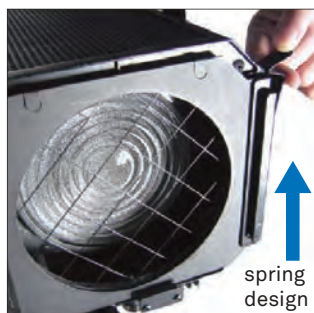

spring design

Spring at side of front panel for efficiently setting gel frame; a lightweight folded steel gel frame is supplied.



Positive and friction disk ensures firm yoke locking; bakelite knob for greater heat resistance.



Hinge design

Hinged lamp tray for easily lamp replacement and reflector cleanup without additional tool.



Front and rear screw-pole focusing knobs for precise focal adjustment with comfort and safety.



Safety wire location hole on the rear plate for easily access

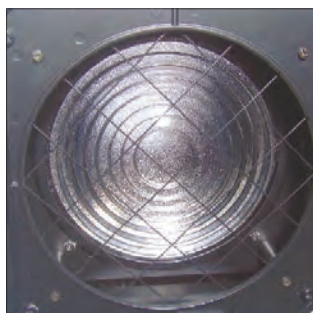

Concentric ripple Fresnel lens casts soft and even light beam projection

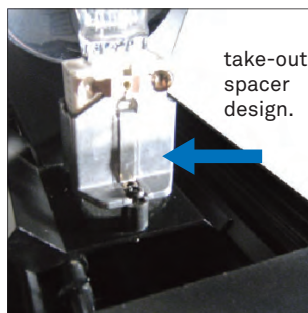

take-out spacer design.

Taking out lamp spacer turns 1000W to 1200W, and 500W to 650W fixture



Constructed of high tensile aluminum extrusion and high pressure die-cast, for max. durability and lightweight

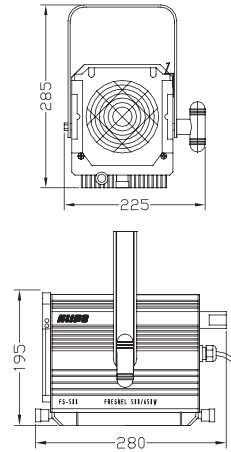

Photometric Data: Calculate for spot & flood focus from peak candela reading.

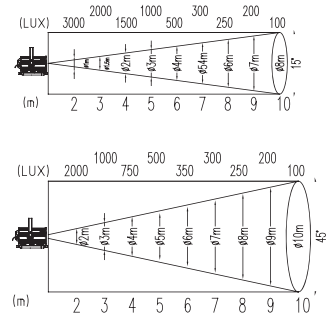

FS-500 Fresnel Spotlight 500 / 650W

Fresnel spotlight 500 / 650W; lampholder GY9.5, Lamp: T18/500W; T26/650W, Black (take-out lampbase spacer for 650W).

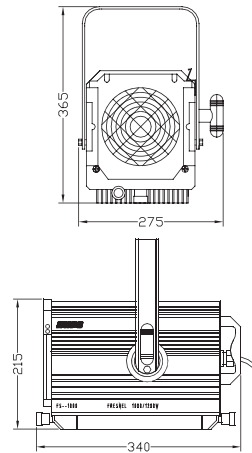

Photometric Data: Calculate for spot & flood focus from peak candela reading.

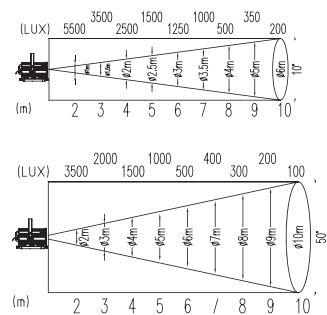

FS-1000 Fresnel Spotlight 1000 / 1200W

Fresnel spotlight 1000 / 1200W; lampholder GX9.5, Lamp: T19/1000W; T29/1200W, Black (take-out lampbase spacer for 1200W).

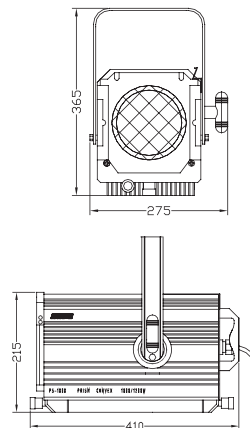

Photometric Data: Calculate for spot & flood focus from peak candela reading.

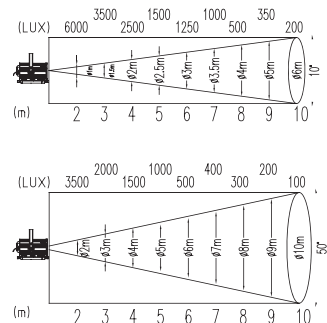

PS-1000 Prism Convex Spotlight 1000 / 1200W

Prism convex spotlight 1000 / 1200W; lampholder GX9.5, Lamp: T19 / 1000W; T29/1200W, Black (take-out lampbase spacer for 1200W).



BDR-FS05

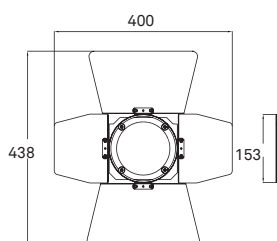

BDR-FS10

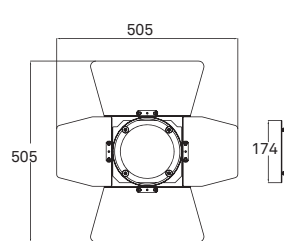

BDR-FS05 Barndoor

BDR-FS10 Barndoor



GY-9.5 Socket

GX-9.5 Socket

Kupo audience blinders have been designed for PAR36 ACL 28V 250W or DWE 120V 650W lamps. Consist of sturdy and thick gauge of aluminum alloy metal sheet, the fixtures are rigid and lightweight. Black anodized finish with a strong, adjustable bracket. The rear plate with louver for better ventilation and keeping lamp life longer. The heavy duty yoke with positive lock off and T bar enables this unit to be set at any angle. Each bank can be adjusted. Both PAR64 and MR16 are delivered prewired without light sources. Please specify on order when wiring service is required.



Lamp retaining ring in allowable dimension for accommodating lamp easier.



Louver pattern hole at rear plate for excellent ventilation.



Easier and user-friendly lamp replacement and wiring through screw-fasten rear plate design.



Sturdy yoke with large positive yoke lock for strong holding force.

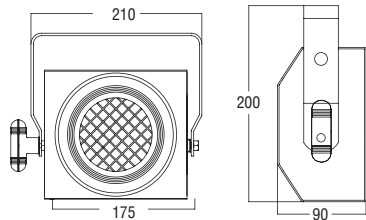

SB-361 1-Lite Blinder

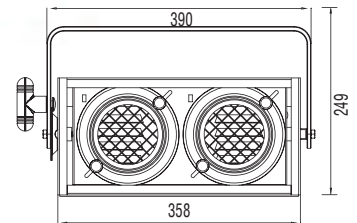

SB-362-I 2-Lite Blinder Unwired

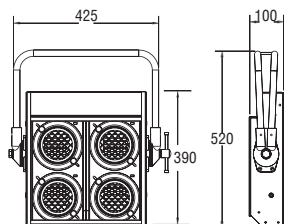

SB-364 4-Lite Blinder Unwired

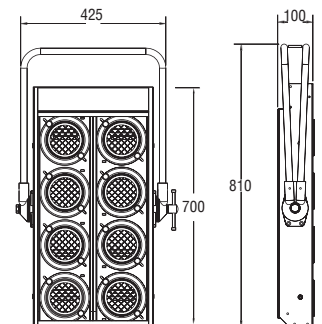

SB-368 8-Lite Blinder Unwired



Horizontal mounting plate



SB-368HY

Optional Horizontal Yoke (only)

With the optional horizontal yoke, SB-368V can be set in both vertical and horizontal direction.

SB-368V 8-Lite Vertical Unwired (with Horizontal Mounting Plate)

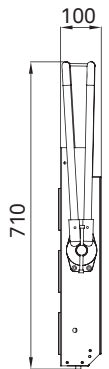
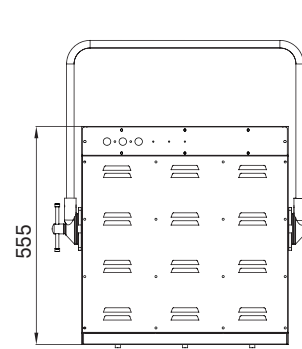
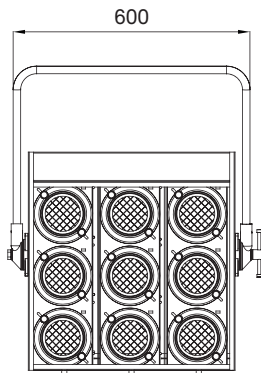

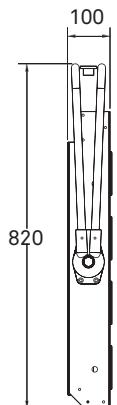
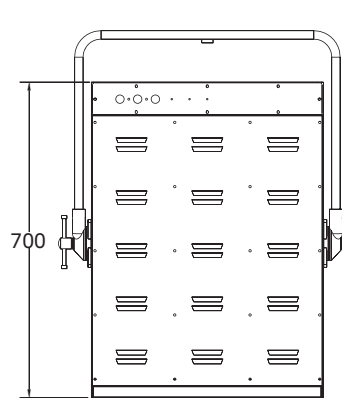
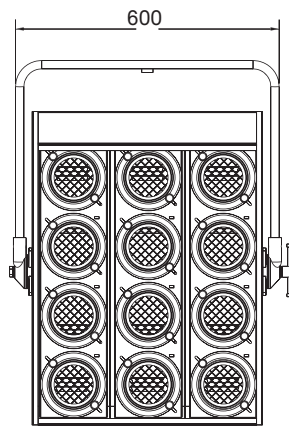

SB-369 9-Lite Bank Lite, Unwired



SB-3612 12-Lite, Unwired

Ideal for many stages and venues, Xenon Followspot features quick trigger and play. The cold mirror reflector makes heat pass behind and gives high visible light forward. Three cooling fans help provide better ventilation. Four rear knobs are designed for easier adjustment of lamp position. The entire set of Kupo followspot includes a ballast, stand, lamp and fixture itself. Full range of 1,000, 2,000, 3,000 and 4,000W Xenon Followspots. High quality engineering, blending ruggedness with a compact lightweight design, gives precise fingertip control of one of the world's most manoeuvrable and powerful Xenon Followspots.

Features

1. The edge of the Iris of Kupo Xenon Followspot is smooth.
2. The operation is easy and with good safety.
3. A micro-switch (safety ring) of the lamp housing for safety. If the lamp housing is opened the power would be automatically shut off.
4. Cold mirror coating for heat transmission to support high infrared transmission and high visible light reflection.
5. Xenon Lamp  is stable at color temperature 6,000K (5,600K), high range of projection (for application in stadium, event and concert) and long life (1,000hrs), especially no need stand-by (warm up) time.
6. The ignitor is small which brings the output more focus and long distance. 

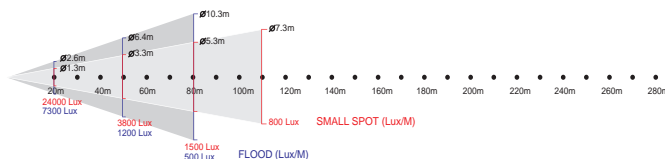
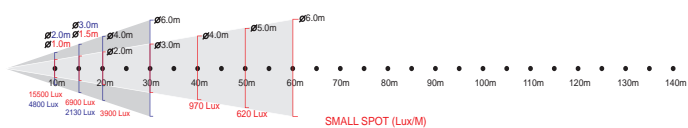

KSX-1000W Followspot

- 1KW followspot
- Color changer: 3kg
- Ballast: 25kg
- Weight: 34kg
- Stand: 33kg
- Lamp: Xenon 1000W

XS-2000W Followspot

- 2KW followspot
- Color changer: 4kg
- Ballast: 25kg
- Weight: 50kg
- Stand: 33kg
- Lamp: Xenon 2000W

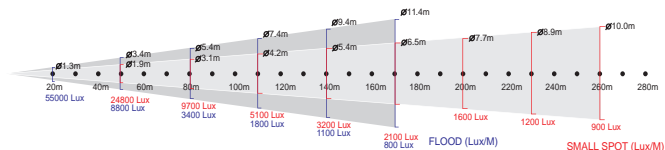
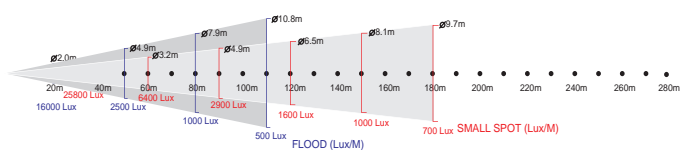

XS-3000W Followspot

- 3KW followspot
- Color changer: 4.5kg
- Ballast: 25kg
- Weight: 70kg
- Stand: 35kg
- Lamp: Xenon 3000W

XS-4000W Followspot

- 4KW followspot
- Color changer: 5kg
- Ballast: 30.5kg
- Weight: 85kg
- Stand: 35kg
- Lamp: Xenon 4000W

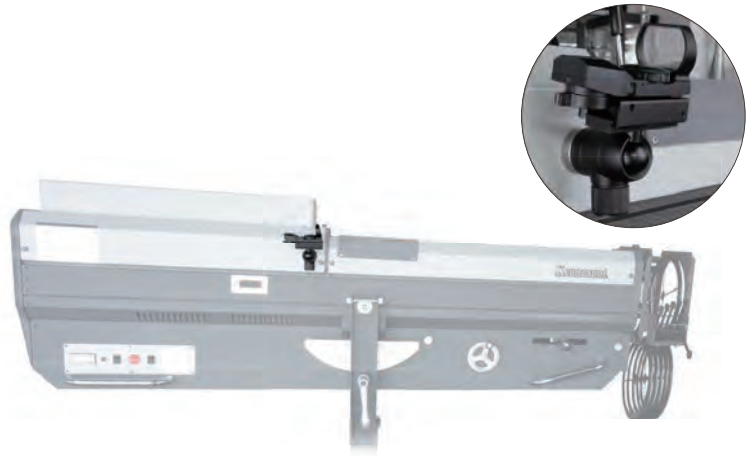

SD03K Followspot Sight

SD03K followspot sight is a compact and handy gadget, helping followspot operator to track and sight the performer on stage precisely.

Specification

- | | |
|--|--|
| 1. Material: Aluminum alloy with black hard anodized surface treatment. | 4. Battery: CR2032, 3V Lithium battery |
| 2. Weight: 250g (without case); 680g (with case) | 5. Dimension: 7.9cm (L) x 5.3cm (W) x 11.7cm (H) |
| 3. Including storage case (x1), Allen wrench(x2) and lens rubber cover(x2) | 6. Case Dimension: 17.5cm (L) x 17cm (W) x 7.5cm (H) |



With rotary knob, user can choose green or red viewing sight at 5 different brightness levels; more comfortable to target and view.



4 reticle patterns offer the viewing comfort for the operator.



Ball-joint design makes the angle adjustment quickly; while knob is tightened, it move no further.



Magnet with large round base for attaching to followspot firmly.



Battery compartment is located atop, making battery change convenient.



Storage case keeps this gadget secure on-the-go.

PAR16 birdie, PAR20, and PAR30 are now ready for LED lamps. Made with classic aluminum barrel, par can for LED light source is built up with dedicated ceramic lamp holder or accessory for making the luminaire working well with LED bulb.



A combination of PAR16 birdie and 2-wire track transformer, this luminaire accommodates a LED MR16 lamp (not included) for the track mount illumination. Gel color frame is included. Feasible for SORAA LED MR16 or other brands.

Transformer Specification

- Input Voltage: AC/100-260V, 50/60Hz
 - Input Current: 270mA
 - Output Current: 1A
 - Output Voltage: DC/12V
- (Output with overload and short circuit protection)

Part Number	Description
SP-16LP-LED	PAR16 with 2-wire 12V/12W track transformer, long nose, polish, G5.3 base (without LED lamp)
SP-16LB-LED	PAR16 with 2-wire 12V/12W track transformer, long nose, black, G5.3 base (without LED lamp)
SP-16SP-LED	PAR16 with 2-wire 12V/12W track transformer, short nose, polish, G5.3 base (without LED lamp)
SP-16SB-LED	PAR16 with 2-wire 12V/12W track transformer, short nose, black, G5.3 base (without LED lamp)
BDR-16B	Barndoor for PAR-16, black
BDR-16P	Barndoor for PAR-16, polish

PAR16 birdie with GZ10 lamp socket, for working directly with AC120V or AC240V GU10 LED bulb.



PAR20 and PAR30 are made with E27 ceramic socket, for using E27 LED bulb directly. Feasible for SORAA PAR20 and PAR30 LED bulb and other brands.



Part Number	Description
PAR-16LP/GZ10	PAR16, long nose, polish, GZ10 base with power lead (without LED lamp)
PAR-16LB/GZ10	PAR16, long nose, black, GZ10 base with power lead (without LED lamp)
PAR-16SP/GZ10	PAR16, short nose, polish, GZ10 base with power lead (without LED lamp)
PAR-16SB/GZ10	PAR16, short nose, black, GZ10 base with power lead (without LED lamp)
PAR-20LP	PAR20, long nose, polish, E27 base with power lead (without LED lamp)
PAR-20LB	PAR20, long nose, black, E27 base with power lead (without LED lamp)
PAR-20SP	PAR20, short nose, polish, E27 base with power lead (without LED lamp)
PAR-20SB	PAR20, short nose, black, E27 base with power lead (without LED lamp)
PAR-30P	PAR30, long nose, polish, E27 base with power lead (without LED lamp)
PAR-30B	PAR30, long nose, black, E27 base with power lead (without LED lamp)

Introducing a new series of LED shop lighting. This new luminaire is constructed with extruded aluminum housing, lightweight yet sturdy. Treated with black powder coating for less visibility. It comes with a Citizen 12W COB white LED for the stable and outstanding light output. A great variety of accessories are available for making the luminaire much more versatile and feasible to diverse applications such as museum, art gallery, boutique shop and the likes.

Features

- Housing is made of aluminum alloy, lightweight yet robust.
- CRI 90 Citizen COB white LED ensures the great performance of the light.
- Comprehensive accessories are available for different specific requirements.
- Threaded attachment design for changing accessory easily.



Specification

- Input Voltage: AC/100-240V
- Light Source: 12W COB white LED (Citizen)
- Luminous Efficacy: 100 lm/w
- Color Render Index: >90
- Color Temperature: 3000K (standard), 2700K or 4000K (optional)
- Optic Lens: 38 degree
- Fixture Material: Aluminum with black finish (standard)
- Track Transformer: 2-wire, or 4-wire system
- Optional Accessory: Barndoor, honeycomb, half top hat, gobo projector
- Control: On/off (standard); Phase-cut, 1-10V or DALI dimming (optional)

The selection of optical LENS refer to the following:



ZSL-LDA
Double Asymmetric
45 degree x 2

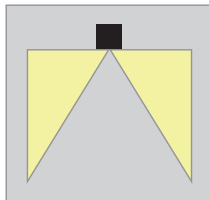

ZSL-L12
12 degree



ZSL-L24
24 degree



ZSL-L38
38 degree



ZSL-L45
45 degree



ZSL-L60
60 degree

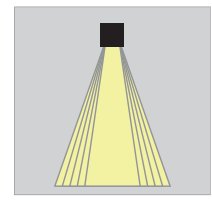

12° 24° 38° 45° 60°



ZSL-LWW
Wall Wash

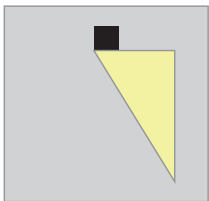

ZSL-LR60
Rectangular 60 x 60 degree
ZSL-LR90
Rectangular 90 x 90 degree

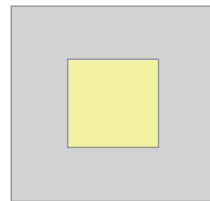

ZSL-L1750
Oval 17 x 50 degree

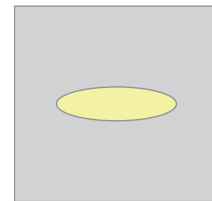

Accessory refers to the following:



Barndoor



Honeycomb



Half Top Hat



Gobo Projector

ZSL-1201 12W COB LED Shop Light, 3000K, 38 degree lens, with 2-wire track transformer, black

ZSL-1202 12W COB LED Shop Light, 3000K, 38 degree lens, with 4-wire track transformer, black

ZSL-BDR Barndoor for ZSL light, black

ZSL-HC Honeycomb set for ZSL light, black

ZSL-HTH Half Top Hat for ZSL light, black

This Outdoor LED Gobo Projector uses Cree LED technology for excellent brightness and dependability in projecting images. Its aluminum alloy casing has an IP65 protection rating, and a top vent maintains pressure and temperature to prevent water buildup, making it suitable for various outdoor environments. It's perfect for both workplace and event image projection needs.



Specification

- Power Input: AC100-240V, 50/60Hz
- Power Consumption: 82W
- LED Source: 80W CREE high power white LED
- Control: Stand-alone (on/off rotation)
- Gobo size: diameter 37.50mm (effective image dia. 24mm)
- Beam angle: 15° to 60° adjustable
- Projection distance: 15 to 20 meters in dark environment
- Protection grade: IP65
- Working environment: -20°C ~ 45°C
- N.W.: 3.7kg
- Dimension: 270(L) x 220 (W) x 200(H)/mm

ZGP-80P LED Gobo Projector

80W LED gobo projector, IP65



High definition optical focal lens is adjustable by turning clockwise or counter-clockwise to get the clear projection image. Make the inner ring with gasket to contact the housing firmly for waterproof seal.

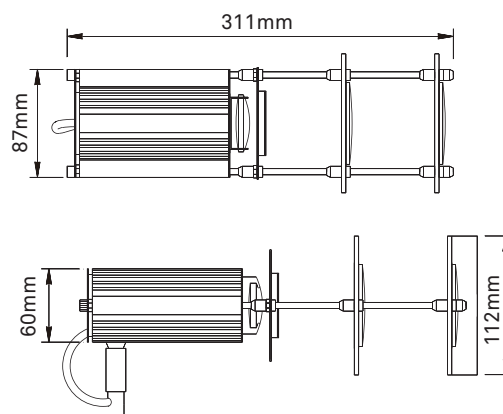

Item	Mounting Type	Transformer	Illuminating Image
UT-310B	Track or Ceiling	No	Metal/Glass Gobo
UT-310W	Track or Ceiling	No	Metal/Glass Gobo
UT-320W	Stand-Alone	Yes	Metal/Glass Gobo
UT-330B	Track or Ceiling	No	Slide Film
UT-330W	Track or Ceiling	No	Slide Film
UT-340B	Stand-Alone	Yes	Slide Film
UT-340W	Stand-Alone	Yes	Slide Film

KUPO's lighting track systems offer designers a minimalist yet versatile solution. They feature sleek, clean designs with precise performance capabilities, suitable for various lighting needs. The product line includes single to three-circuit tracks, a wide range of accessories, and excellent compatibility with major track systems from other brands. These systems hold numerous world-recognized certifications such as ENEC, UL, cUL, TUV/GS, and PSE, ensuring reliable and precise connectivity for lighting applications.

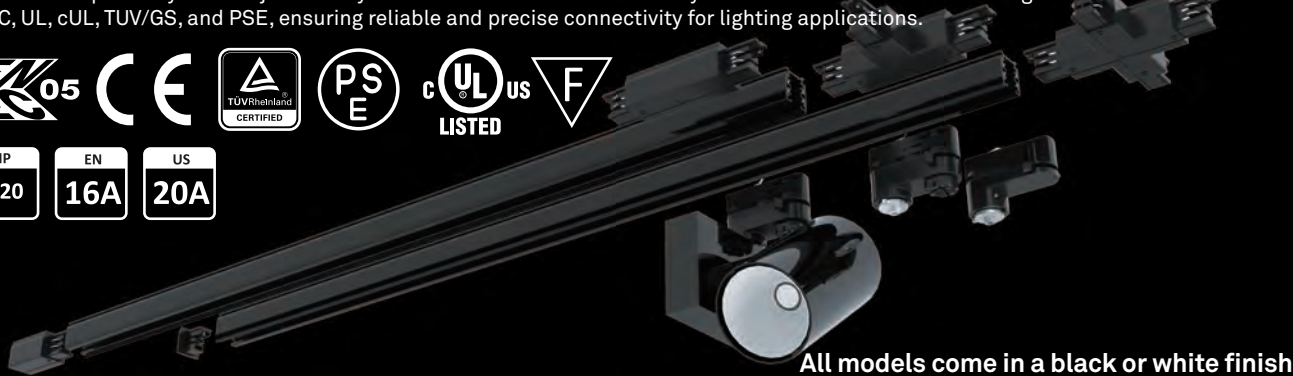

All models come in a black or white finish

Lighting Track Code Based

Type No.	Wire	Aluminum Extrusion Length★	Finish
W-	2	10	1000mm
	3		
	4		
J-	6	20	2000mm
	1		
JS-	1	30	3000mm
N-	1		

★ Other length depend on request

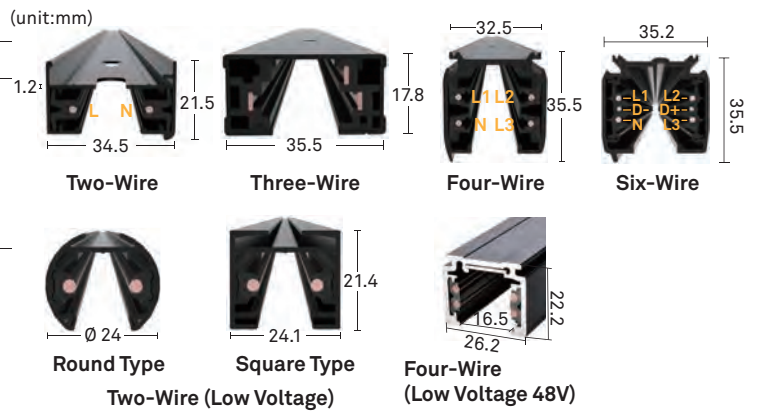

Two-Wire (Low Voltage)

Single-Phase, 1-Circuit, 12-48Vdc, 25A max.

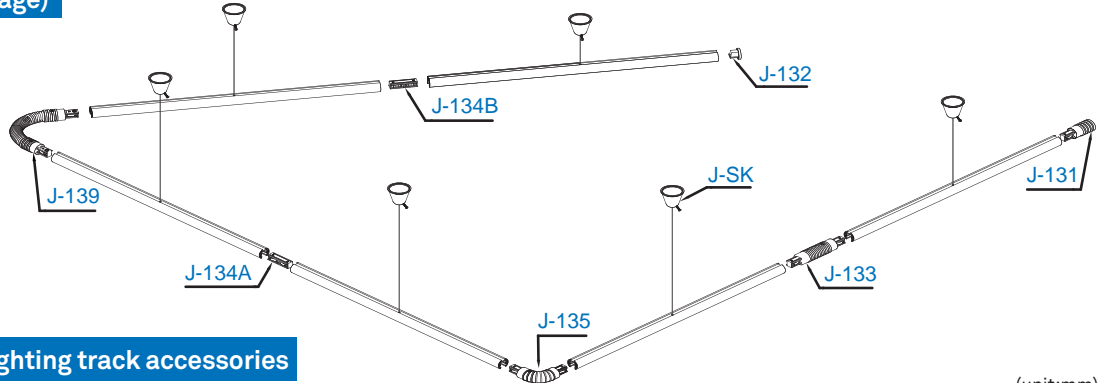

A diverse range of lighting track accessories

	Power End Connector	End Cap	Mini Straight Connector	Straight Connector	L Connector	T Connector
Two-Wire	W-231 (35x75)	W-232 (34x19.3x4)		W-234 (8.5x79)	W-235 (35x70)	W-236 (105x35x35)
Three-Wire	W-331 (35x69x107)	W-332 (3x35x17x12.7)	W-333 (35x3x79)	W-334 (103x35x178)	W-335 (108x70x35x35)	W-336 (180x105x108x35x35)
Four-Wire (3 Circuits)	W-431 (L/R) (34x65x98)	W-432 (29.5x32.5x31.5)	W-433 (3x31x68)	W-434 (99x34x166)	W-435 (34x99x66x32.5)	W-436 (166x99x34x66x100x32.5)
Six-Wire (3 Circuits)	W-631 (L/R) (139x34)	W-632 (35x31)	W-633 (21x107)	W-634 (13x77x203)	W-635 (45x108x10x83)	W-636 (203x77x10x119x45)
Low Voltage (2-Wire)	J-131 (26x67)	J-132 (24x18)	J-133 (26x128)	J-134 (15x47)	J-135 (24x83)	
Low Voltage (4-Wire)	N-131 (16x17x97)	N-132 (21.87x26.14)	N-133 (16x144)		N-135 (16x114)	

Four-Wire (Low Voltage 48V)

Single-Phase, 2-Circuit, 48Vdc, 16A max.



Single-Phase, 1-Circuit, 48Vdc, 16A max. + DALI Control



An optional metal strip enables the installation of magnetic luminaires, even the track is mounted vertically.

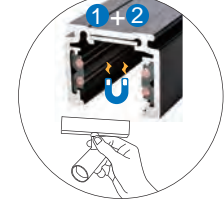

2/3/4/6-Wire

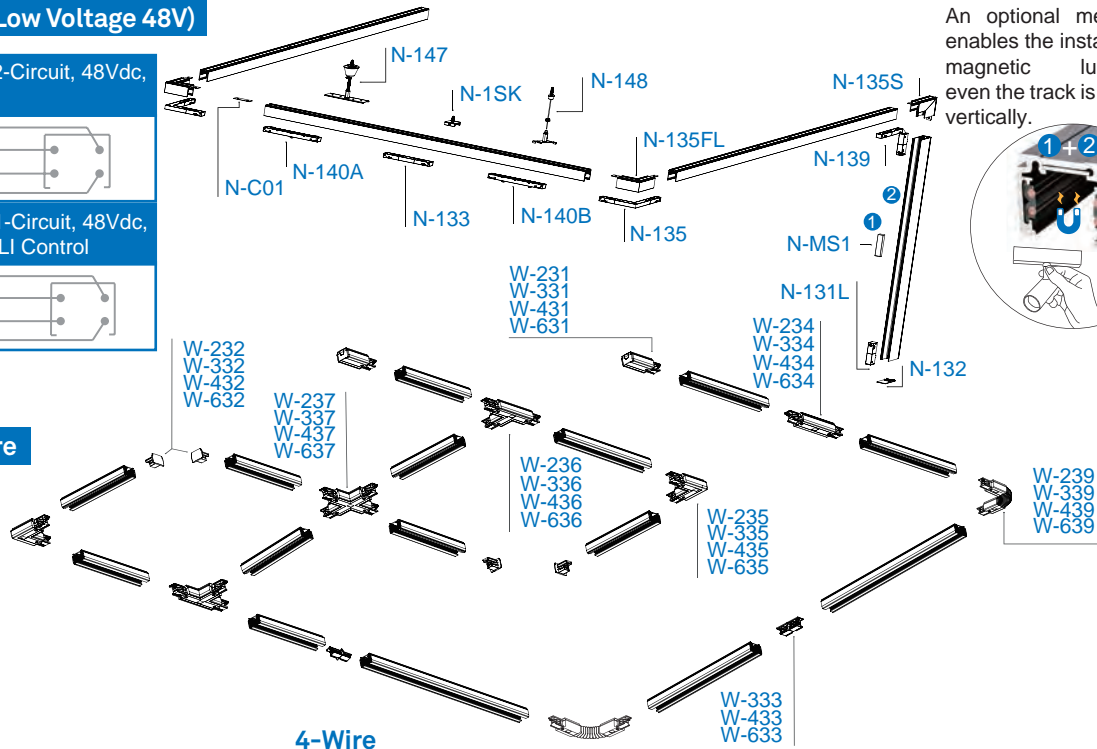

2-Wire

Single-Phase, 1-Circuit, 120Vac 20A Max / 220-250Vac 16A max.

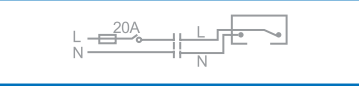

3-Wire

Single-Phase, 1-Circuit, 120Vac 20A Max / 220-250Vac 16A max.

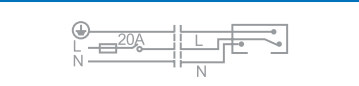

4-Wire

Single-Phase, 1-Circuit, 120Vac 20A Max / 220-250Vac 16A max.

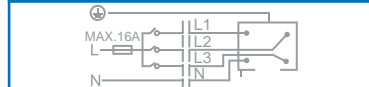

Tri-Phase, 1-Circuit, 230 / 400Vac 16A max.

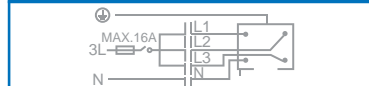

Tri-Phase, 3-Circuit, 230 / 400Vac 16A max.

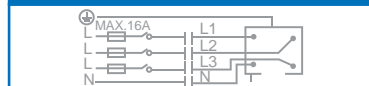

6-Wire

Tri-Phase, 3-Circuit, 230/400Vac 16A max. + DALI Control

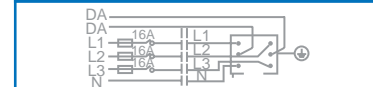

Single-Phase, 3-Circuit, 220-250Vac 16A max. + DALI Control

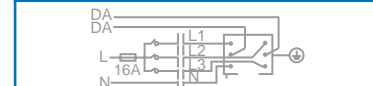

(unit:mm)

X Connector	Live End Conduit Filter	Flexible Connector	Pendant Adapter	Suspension Kit
W-237 105 35	W-238 35 147.6	W-239 75 78	W-240 30 40 58	W-448N
W-337 105 35 180	W-338 35 107 145	W-339 35 69 107 173 248	W-340 36 64 38	W-447
W-437 166 99 34		W-439 33 245 34 80 179	W-440 84 55 32.5	D-480 74 34 46 87 52 32.5
W-637 203 77		W-639 182 35 285	D-680 113 30	W-448
		J-139 316 25	J-140 (A/B) 75 28	J-SK
		N-139 228.8 16 17	N-140 R4 16 170 18.5 25.4	D-680 113 30
			N-147 53.42 39.43 30.4	N-148 53.42 57.5 30.4

POLE-OPERATED YOKE

The pole-operated yoke is a custom part to replace the light's existing yoke and have the light controlled from below. Fitted with two cups that control tilting and panning, the yoke enables user to make the adjustment on the ground with a telescopic operating pole. The pole-operated yoke is equipped with a 28mm junior spigot for mounting to a clamp.

Model-A

A junior spigot is supplied for fitting to a clamp or 28mm receiver.

Pan and tilt adjustment is carried out by worm gear mechanical design.

Model-B

170-250mm

Pole-operated yoke is a customized part as the light's dimension varies from each brands.

YOUTUBE
KUPO POLE OPERATED YOKE

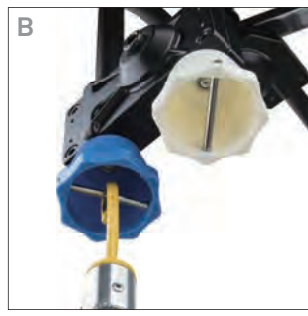
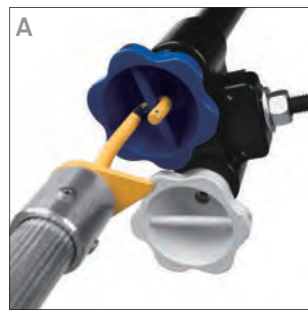

Adjustment via a telescopic operating pole from the ground staff.

Blue cup adjusts the pan (left or right.) White cup adjusts the tilt (up or down).

Kupo Telescopic Operating Pole is made of aluminum alloy tube with black anodized surface finish. Constructed of four sections with three risers. While completely extended, it reaches 4M long for KCP-144, and 6.4M long for KCP-206. Each section comes with a quick-release clamp for easier lockup. Top hook helps to maneuver the panning, tilting and focusing of luminaire mounted at high position in the studio. Top hook is interchangeable with L-shape top hook, made with a horizontal prolonged rod, for the control the lighting fixture effortlessly. Aluminum pole diameter 20, 25, 30, and 35mm.

KCP-144

Telescopic Operating Pole (1.3M-4M), with classic top hook

KCP-206

Telescopic Operating Pole (1.9M-6.4M), with classic top hook

KS-211

L-Shape Top Hook for Telescopic Operating Pole



Classic Top Hook



Spin-free connection between tubes is user-friendly, making the operation easy. Quick release tube clamp for instant lockup firmly.



YOUTUBE
KUPO TELESCOPIC OPERATING POLE (KCP-144 & KCP-206)



Laser-engraved arrow helps to fast figure out the direction of top hook.



Telescopic operating pole is used to control the lighting fixture mounted high at the studio.



L-Shape top hook (KS-211) for effortless lighting control; interchangeable with classic top hook.



Removable handle is space saving for transportation and storage.

IRIS Offering a great method for precise and smooth lighting control.

Features are shown as below:

1. aperture size adjustable from 4.5 mm to 75 mm.
2. has anti-heat absorbing radiance characteristic.
3. 3 fixed focusing hole for quick and easy positioning.
4. formulated gray painting provides as superior heat resistant as up to 450°C for stainless steel leaves.
5. tailor-made backing plate available upon request.



YOUTUBE
IRIS FOR
LIGHTING CONTROL

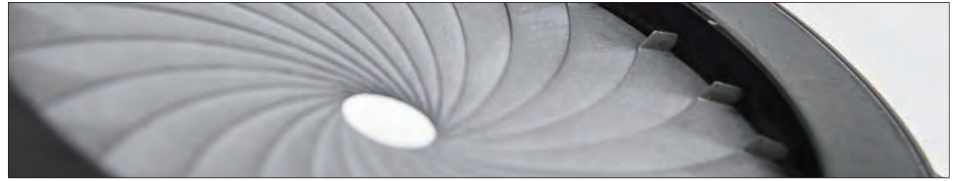

ETI-F18

18 Leaves For S4, Shakespeare, S6 Series

A: 120 mm C: 13 mm
B: 137 mm D: 102 mm



ETI-F24

24 Leaves For S4, Shakespeare, S3 Series, Marumo Rayer

A: 120 mm C: 13 mm
B: 137 mm D: 102 mm

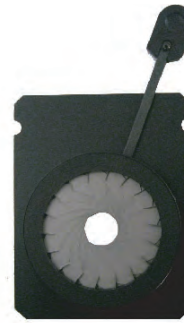

ETI-P18

18 Leaves For Pacific, Freedom

A: 118 mm C: 13.5 mm
B: 153 mm D: 102 mm



ETI-FJ18

18 Leaves For S4 junior

A: 80 mm C: 12.5 mm
B: 110 mm D: 78 mm



ETI-S24

24 leaves for SL

A: 107 mm C: 14 mm
B: 115 mm D: 102 mm



ETI-W24

24 Leaves Iris Shutter (Open To Fully Close)

A: 120 mm C: 13 mm
B: 137 mm D: 102 mm



ETI-A20

20 Leaves Iris for Acclaim

A: 95.6 mm C: 14.6 mm
B: 140 mm D: 89 mm



ETI-M12

IRIS for Moving Head

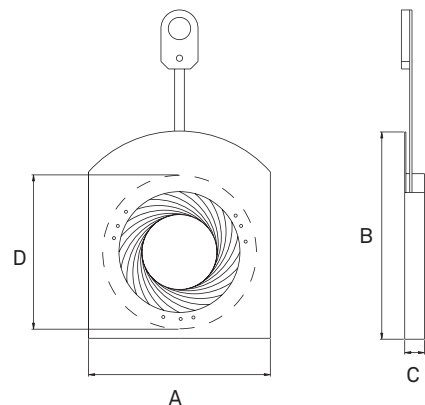



2.5": 18 leaves Iris for dia 46 mm aperture.



3": 18 leaves Iris for dia 52.6 mm aperture.



4": 18 leaves Iris for dia 75 mm aperture.



5": 18 leaves Iris for dia 90 mm aperture.

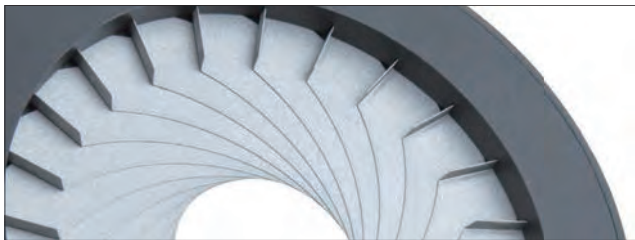

24-leave Iris for dia. 75mm aperture.



16-leave Iris for dia. 42mm aperture.



16-leave Iris for dia. 45mm aperture.



18-leave Iris for dia. 100mm aperture (with fully close shutter).



Features

- Fits for renowned ETC Source Four ellipsoidal spotlight.
- Universal power input AC/100-240V for plug and play.
- Gear drives the iris movement silently.
- DMX in and out for signal daisy chain.
- Working status clearly shown on power and signal LED indicator.

Specification

- Robust metal frame with durable black coating.
- Standard 5-pin XLR in and out signal connector.
- IEC Universal Power plug for AC/100-240 input.
- DIP switch for simple DMX addressing.

DMX-IRIS 18 Leaves DMX Iris

Constructed by classis 18-leave stainless steel Iris and motorized by standard DMX-512 signal, drop-in DMX Iris provides an easy way for controlling the light beam of traditional theater lighting fixture remotely and precisely.



LED lights up while the AC power comes in.

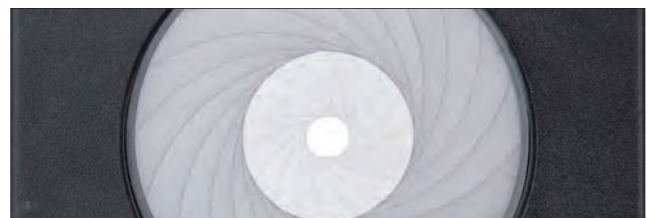

Fabricated of stainless steel 18-leave Iris.



Intelligent leverage rotary device firmly lock down the DMX Iris with ellipsoidal so there is no worry if it is used upside down, side mounted, or even with Auto-Yoke (pan and tilt).



Rotating the knob to manually operate the Iris while no power is required or connected (manual mode).



“Zero” switch is the initial aperture position where it can be set at fully closed or open as default. Check button is the self-examination function to inspect the unit works or not.



IEC and standard 5pin XLR receptacles neatly position at chassis atop.

Theater lighting design is a matter of art. With comprehensive lighting control accessories, we help the luminaries delivering precise light projection and accurately performing what you expect for. Making your lighting design a truly piece of art.



Top Hat is shaped in cylinder with a hole for light to pass through, but taking away the glint of lighting fixture directing to the audience. It is a light control device to shelter the audience eyes from the direct light source. It is treated with matt black paint so as the glare can be reduced, and the snoot is physically to eliminate the light spill.

ETP-T6/T3

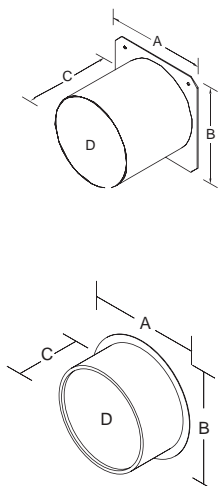

Product	Description	A	B	C	D
ETF-T5	S4, SL, SHAKESPEARE, SELECON Pacific/SPX	159	159	126	126
ETP-T6	6"LEKO	191	191	152	152
ETF-T3	SHORT S4, SL, SHAKESPEARE, SELECON Pacific/SPX	159	159	76	126
ETP-T6S	S4 ZOOM, S4 PAR, PARNEL, 6" LEKO, 360Q	191	191	152	171
ETP-T3S	S4 ZOOM, S4 PAR, PARNEL, 6" LEKO, 360Q	191	191	76	171
ETF-T10	S4 10 DEGREE, SL 10 DEGREE	305	305	252	252
ETF-T12	S4 5 DEGREE	354	354	302	307
ETH-64	PAR64 (ALTMAN AND L&E)	254	254	202	202
ETH-643	SHORT PAR64 (ALTMAN AND L&E)	254	254	76	202
ETH-16	PAR16	73	73	51	51
EAP-T6	S4 PAR ROUND FRAME, S4 ZOOM, S4 PARNEL	191	191	152	166

Size: mm

Half Top Hat is functioning like top hat, but just with half cylinder, therefore the light spill blocking is subject to the desired direction where the half top hat is placed.

EAP-H6/H3

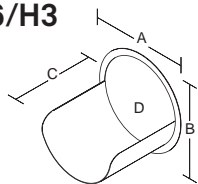

Product	Description	A	B	C	D
ETF-H5	S4, SL, SHAKESPEARE, SELECON Pacific/SPX	159	159	126	126
ETF-H3	SHORT S4, SL, SHAKESPEARE, SELECON Pacific/SPX	159	159	76	126
ETP-H6	S4 ZOOM, S4 PAR, PARNEL, 6" LEKO, 360Q	191	191	152	166
ETP-H3S	S4 ZOOM, S4 PAR, PARNEL, 3" LEKO, 360Q	191	191	76	166
ETF-H8	PAR64 (ALTMAN AND L&E)	254	254	202	202
ETF-H10	S4 10 DEGREE, SL 10 DEGREE	305	305	252	252
ETF-H12	S4 5 DEGREE	354	354	302	307
ETP-16	PAR16	73	73	51	51
EAP-H6	S4 PAR ROUND FRAME HALF TOP HAT 6"	191	191	152	166
EAP-H3	S4 PAR ROUND FRAME HALF TOP HAT 3"	226	226	76	166

Size: mm

ETP-H6/H3

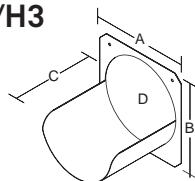

Pattern holder is a metal frame made to accommodate a metal gobo, leaving the metal free from warped. Heat-resistance plastic knob is mounted atop for convenient utility. It is placed directly in the focal plane of the fixture so as to project the image. Glass holder is also available for a glass gobo to fit in.

ETF-PA/PB/PD

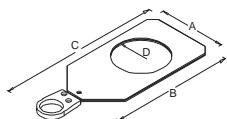

ETF-PM

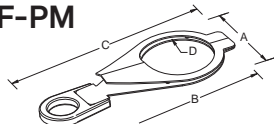

ETF-GM

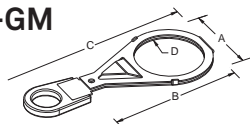

Product	Description	A	B	C	D
ETF-PA	A SIZE PATTERN HOLDER FOR S4	94	174	228	81
ETF-PB	B SIZE PATTERN HOLDER FOR S4	94	174	228	70
ETF-PD	B SIZE PATTERN HOLDER FOR SELECON PACIFIC/SPX	114	193	250	70
ETF-PE	A SIZE PATTERN HOLDER FOR SELECON PACIFIC/SPX	114	193	250	81
ETF-GHS	86mm OD GLASS (GOBO SLOT) PATTERN HOLDER FOR S4	94	184	238	70
ETF-GH	82mm OD GLASS (GOBO SLOT) PATTERN HOLDER FOR S4	94	184	238	70
ETF-GHD	86mm OD GLASS (GOBO SLOT) PATTERN HOLDER FOR SELECON PACIFIC/SPX	114	193	250	70
ETF-PM	M SIZE PATTERN HOLDER FOR S4 JUNIOR	69	109	157	54
ETF-GM	M SIZE GLASS HOLDER FOR S4 JUNIOR	69	109	162	54

Size: mm

Color Extender is the combination of gel frame and top hat; two functions in one device. Gel slot is at the front of the unit, leaving more space for heat to travel and cool down, which eliminates gel burnout.

ETF-CE5/CE3

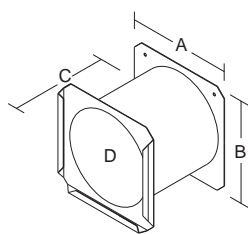

Product	Description	A	B	C	D
ETF-CE5	S4, SL, SHAKESPEARE, SELECON Pacific/SPX	159	159	126	126
ETF-CE3	SHORT S4, SL, SHAKESPEARE, SELECON Pacific/SPX	159	159	76	76
ETF-64CE	PAR64 (ALTMAN AND L&E)	254	254	126	126
ETP-CE6	S4 ZOOM, S4 PAR, PARNEL, 6" LEKO, 360Q	191	191	152	152
ETP-CE3	S4 ZOOM, S4 PAR, PARNEL, 3" LEKO, 360Q	191	191	76	76

Size: mm

Color Frame

ETF-CF

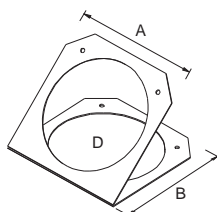

EAP-CF

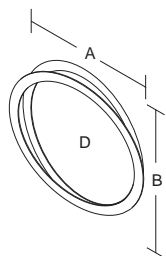

Product	Description	A	B	C	D
ETF-CF137	S4, SL, SHAKESPEARE, SELECON PACIFIC/SPX	159	159	-	137
ETF-CF152	6" LEKO, 360Q	191	191	-	152
ETP-CF172	S4 ZOOM, S4 PAR, PARNEL	191	191	-	172
ETF-CF203	PAR64	254	254	-	203
ETF-CF254	S4 10 DEGREE, SL 10 DEGREE	305	305	-	254
ETF-CF304	S4 5 DEGREE	354	354	-	304
EAP-CF	S4 ROUND FRAME	190	190	-	165

Size: mm

Donut is functioning as top hat, not only eliminating the spill of light but also reducing the lens flare and unwanted scattering light for sharpening the projected patterns and images.

ETF-DT

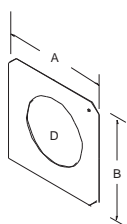

Product	Description	A	B	C	D
ETF-DT	S4, SL, SHAKESPEARE, SELECON PACIFIC/SPX	159	159	-	76
ETF-DT3	6" LEKO, 360Q	191	191	-	76
ETF-DT6	S4 10 DEGREE, SL 10 DEGREE	305	305	-	150
ETF-DT7	S4 5 DEGREE	354	354	-	182

Size: mm

Barndoor is generally constructed of four leaves and attached to the front of lighting fixture to shape the beam of the light. It is usually used for the diffuse light like a Fresnel, flood light, and Par Can, in order to get a more focused coverage field or prevent the light spilling into the areas where it is not wanted. As “profile” light like Source Four has more focused beam, it is rarely used with barndoor.

ETP-BDR2

**ETP-BDR
BDR-64B**

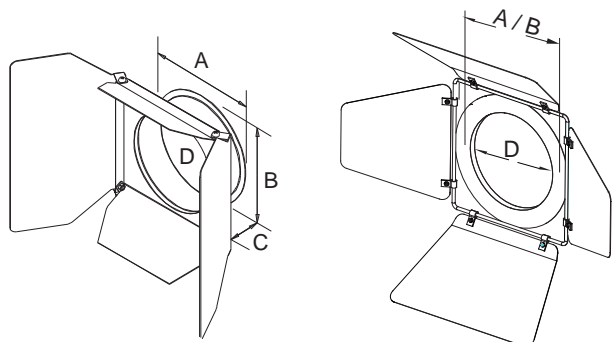

Product	Description	A	B	C	D
ETP-BDR	S4 PAR, PARNEL	191	191	-	162
ETP-BDR2	S4 PAR, PARNEL WITH COLOR EXTENDER	191	191	50	173
BDR-64B	PAR64	264	264	-	218

Size: mm

EAP-L

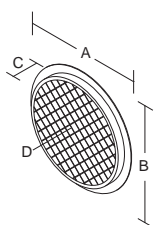

Egg Crate Louver is an architectural accessory and cuts off 45 degree angle of the light. It eliminates the distracting glare, renders more precise light distribution, shields lamps from direct view, and reduces luminaries surface brightness for maximum visual comfort.

Product	Description	A	B	C	D
EAP-L	S4 PAR EGG CRATE LOUVER	191	191	13	166

Size: mm

ETP-CR

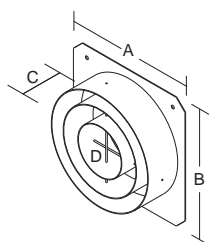

It is built up with three concentric cylinders to get the comparable function to a full 6” top hat but just with only in 2” profile. Concentric ring offers full control of spill and scattering beam for the S4 PAR and ParNel.

Product	Description	A	B	C	D
ETP-CR	S4 PAR CONCENTRIC RING 2”	191	155	51	-

Size: mm

ETF-BB

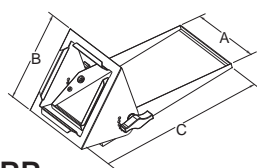

Beam Bender is made with an adjustable mirror so as to change the angle of beam output. It is an ideal and helpful device for projecting the light around irremovable obstructions. The fixture could be concealed, and with beam bender, the light output could reach the area with maximum output.

Product	Description	A	B	C	D
ETF-BB	BEAM BENDER FOR S4	175	155	310	-

Size: mm

Adaptor

ETF-ADP

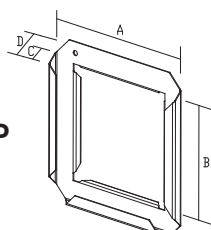

Product	Description	A	B	C	D
ETF-ADP	159mm to 191mm adaptor for S4, SL, SHAKESPEARE, SELECON	192.5	136	12.5	22.5

Size: mm

Dichroic filters are optically coated with dielectric thin films vacuum-deposited onto glass substrate. They transmit light of certain color and reflect the complementary color. Kupo assures the quality filters and the absolute spectral stability that expresses consistent shades and perfect images. No matter applied indoors or outdoors, Kupo dichroic filters are excellently resistant to environmental degradation. We have a comprehensive selection of colors that provides the flexibility for you to choose the suitable ones for your projects.

Color Tolerance

- Within + /-3 nm of designed central wavelength(T50).

Features

- True-to-life colors.
- High transmission of desired light.
- Excellent heat resistance.
- Low maintenance & cost-saving.

Available substrates

- Sodalime Glass: Heat resistance up to 150°C (Thickness: 1.1, 2.0, 2.9mm)
- Borosilicate Glass (D263T): Heat resistance up to 450°C (Thickness: 0.21, 0.3, 0.55mm)
- Borofloat Glass: Heat resistance up to 450°C (Thickness: 1.1, 2.0, 3.3, 3.8mm)

Technical Specification

- Humidity. Adhesion. Abrasion.
- Resistance. MIL-M-13508C.

Applications

- Architectural lighting.
- Entertainment and stage lighting.
- Precise use for electronics and industrial applications.

Available Size

- Square: 7 - 300 mm
- Round: 10 - 425 mm

Installation

To achieve a better effect, it is suggested to install the coated side of filter toward the light source. The filter should be set at the angle of 90 degrees to the light path to avoid undesirable color shift. Moreover, for the best color performance, the filters are not recommended to be placed at an extreme angle greater than 40 degrees in the lighting fixtures.

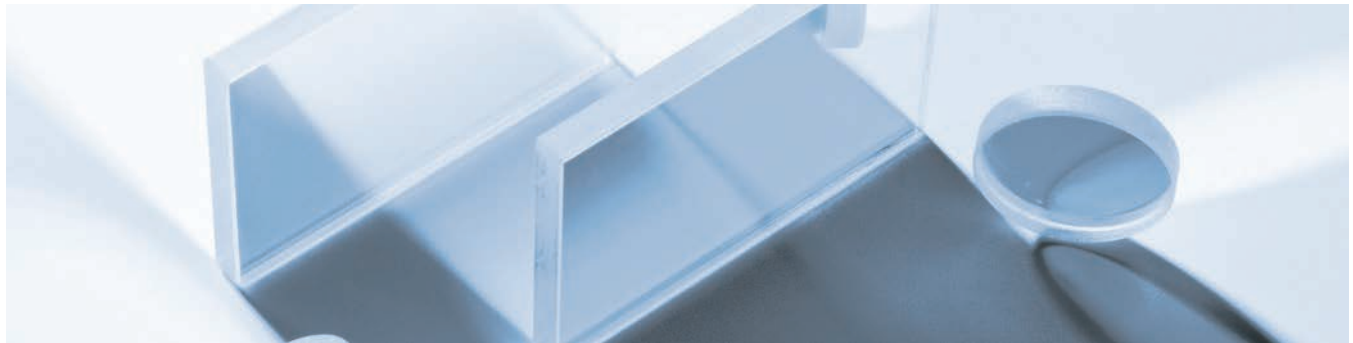

We offer diverse dichroic filters including

- (1) Hot Mirror for Heat Reflection: high infrared energy reflection; block near UV energy for excellent visible transmission; ideal for museum and architecture professions.
- (2) Cold Mirror for Heat Transmission: high infrared transmission; high visible light reflection; ideal for surveillance camera and medical illumination.
- (3) UV Block Filter: high UV energy reflection and high visible light transmission; ideal for art gallery, museum or where the precious objects should be shielded from light damage.
- (4) UV Transmission Filter: UV energy transmission and visible light reflection; perfect for fluorescent effect and tanning facility.



DFS-B Dichroic Sample Book

Characteristics

- 68 standard dichroic colors.
- 6 kinds of colors coorection filters.
- 7 reflective color filters.
- 4 kinds of patterned glass.
- Color Comparison List with Kupo, Rosco and Lee colors.
- Substrate: Borofloat.



Note: Printed colors for reference only, not definitely identical to real dichroic colors.

Longpass Filters

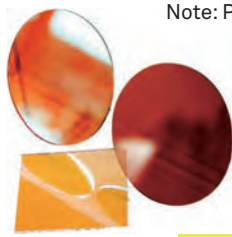
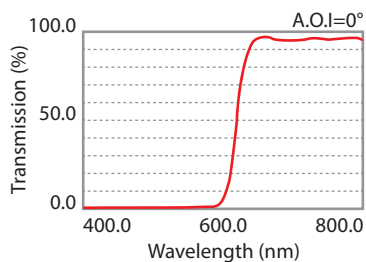

Y1001 SPRING YELLOW	Y1002 MEDIUM YELLOW	Y10103 YELLOW	O2210 GOLD ORANGE	O1911 SUNSET ORANGE	O16412 ORANGE	
Y1019 LIGHT YELLOW	Y76704 CANARY	O10405 AMBER	O01506 STRAW	R2613 FIRE	R2714 RED	R15 RUBY RED
O10520 BURNT YELLOW	O17907 DEEP AMBER	O15808 LIGHT ORANGE	O77809 GOLDEN AMBER	R16 BLOOD RED	R17 DARK RED	R2918 PLASA RED

Bandpass Filters

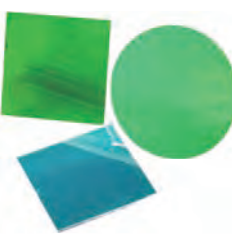
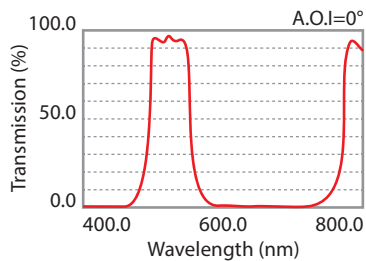

G32502 MALLARD GREEN	G32503 BERYL GREEN	G73813 PALE GREEN	G73814 LIME GREEN	G74015 YELLOW GREEN	
G73504 VELVET GREEN	G13905 GREEN	G73606 DARK GREEN	G2810 LIGHT GREEN	G73611 OASIS GREEN	G2812 FERN GREEN
G73607 JELLY GREEN	G73608 GRASS GREEN	G13909 PRIMARY GREEN	G9017 JADE	G9019 DARK YELLOW GREEN	G72918 SCUBA BLUE

Notch Filters

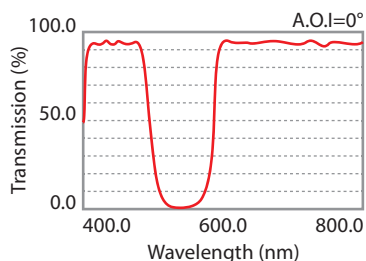

M5601 MAGENTA	M79502 MAGICAL MAGENTA	M79303 VANITY FAIR	M79508 ROSE	M1114 BRIGHT PINK	M32815 PINK	
M79819 CHRYSALIS PINK	M79516 DARK ROSE	M4904 PLUM	M12613 FANTASY MAGENTA	M12617 MEDIUM PURPLE	M16918 PALE LAVENDER	P79909 SPECIAL LAVENDER
M79720 DEEP PINK	M79506 ROSE PINK	M4905 DEEP MAGENTA	P12607 MAUVE	P12610 LIGHT PURPLE	P79711 PURPLE	P79712 DEEP PURPLE

Shortpass Filters

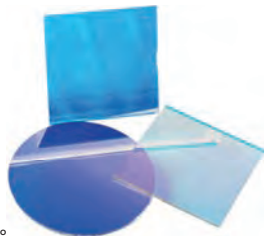
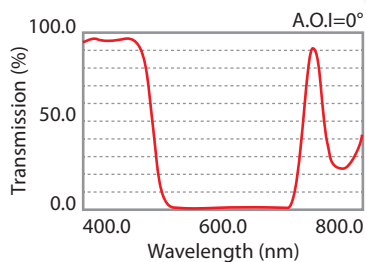

C13116 MARINE BLUE	C35317 LIGHTER BLUE	C35413 STEEL BLUE	B6809 SKY BLUE	B8507 BRIGHT BLUE	B70704 ULTIMATE VIOLET	
C11715 ITALIAN BLUE	C11514 PRACOCK BLUE	B11812 LIGHT BLUE	B0611 BRILLIANT BLUE	B19506 ZENITH BLUE	B71305 BLUE	B18103 DARK BLUE
B18319 MOONLIGHT BLUE	B72118 BARRY BLUE	B71408 ELYSIAN BLUE	B14110 SHINY BLUE	V79902 SPECIAL BLUE	V7101 BLUE-PURPLE	V79920 DEEP LAVENDER

Color Correction Filters

KUPO Optics provides color correction filters that are able to precisely convert the color temperature to what you required. There are full ranges of daylight and tungsten conversion available. For your unique project, definitely we can provide customized filter as well.

KUPO color correction filters are coated with hard dielectric thin-films with great density which makes our filter greatly resists environmental degradation.

Features

- Perfect piece-to-piece, batch-to-batch consistency
- Precise color temperature conversion
- Great resistance of UV and heat (Compared to gel)
- Great endurance of environmental degradation

Examples of Application

- Stage Lighting
- Photography
- Film Studio
- Cinematography

General Specification

- Spectral Tolerance: +/- 5nm at designated wavelength
- Available Substrate: See page 4
- Humidity, Adhesion, and Abrasion: MIL-M-13508C

**Blow conversion result is only for reference.
Actual result will be affected by the light source.**



Tungsten Conversion

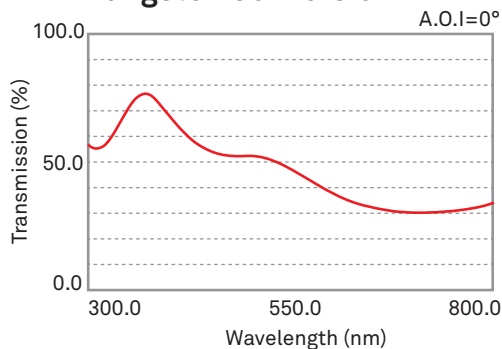

Daylight Conversion

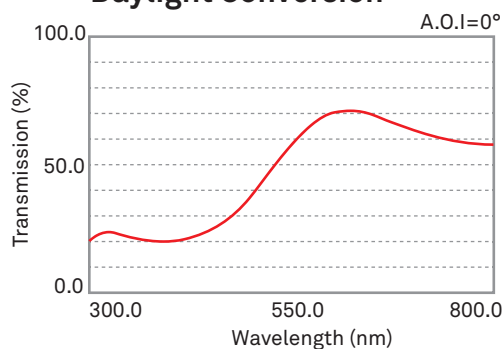

FULL C.T.B CTB-001 3200/6870	HALF C.T.B CTB-002 3200/4260	QUARTER C.T.B CTB-003 3200/3570	CTB-004 3200/5400	CTB-200 3200/10850
------------------------------------	------------------------------------	---------------------------------------	----------------------	-----------------------

FULL C.T.O CTO-001 6500/3000	HALF C.T.O CTO-002 6500/3460	QUARTER C.T.O CTO-003 6500/4740	CTO-008 6500/3100	CTO-009 6500/5300
CTO-010 6500/3500	CTO-011 6500/3400	CTO-013 6500/2550	CTO-014 6500/2700	CTO-015 6500/2560



**YOUTUBE
PRECISION
LASER CLEAVING
SOLUTION (1/4)**



**YOUTUBE
PRECISION
LASER CLEAVING
SOLUTION (2/4)**



**YOUTUBE
PRECISION
LASER CLEAVING
SOLUTION (3/4)**



**YOUTUBE
PRECISION
LASER CLEAVING
SOLUTION (4/4)**

A honeycomb is an essential accessory for any lighting system used to minimize or eliminate glare from normal viewing angle. It is made up of the aluminum foil with a hexagon shape. It can be a shield to prevent the dazzle of illuminator. Honeycomb comes with different degrees to give creative effect. The honeycomb grid should be used in conjunction with a lens as it provides no protection for the lamp. Usually it decrease the center beam brightness by about 20%. Application is typical in up lighting, down lighting, illuminating art or any application where spill light would be objectionable.

Feature

1. Change the shape and intensity of the light output from light source.
2. Lightweight.
3. Dazzle Prevention.

Quality Approval

1. RoHS certification.
2. The consistency of painting coating.
3. No painting fading under UV illumination.
4. Heat resistance of 250°C / 800°C.



Specification

Material: Aluminum Foil.
Color: Black or Silver.

Available Size

Square: 35 mm - 300 mm
Round: 35 mm - 300 mm

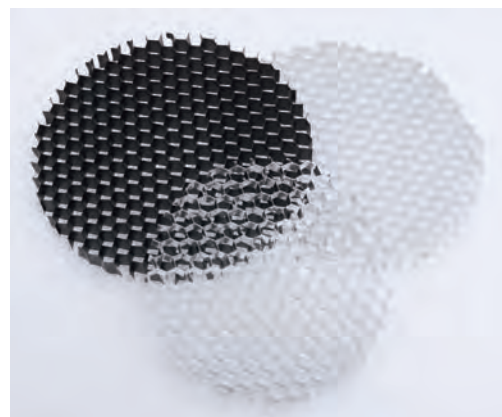
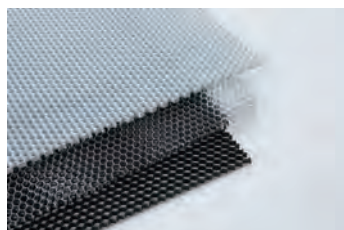

Aperture sizes are available w/ the following dimensions

Cell Size			Cell Depth			Open Area
1/8" (3 mm)	3 mm	-	5 mm	6 mm	-	95 %
3/16" (4.5 mm)	5 mm	6 mm	9 mm	10 mm	-	95 %
1/4" (6 mm)	6 mm	-	10 mm	12.7 mm	20 mm	95 %
Cut Off	45 degree	52 degree	60 degree	65 degree	72 degree	-

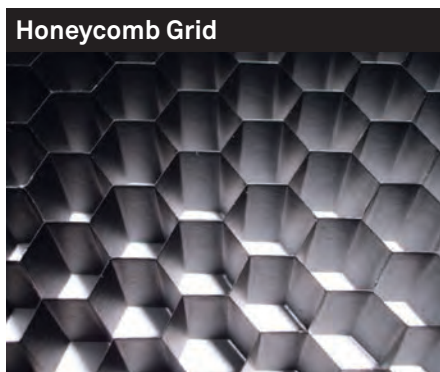

KP-HCH MR16 Honeycomb Holder

This elastic device is made of stainless steel with heat treatment, rendering honeycomb a flexible fit to any brands of MR16 bulb. With four bended teeth on the rim, it could hold the honeycomb firmly in the position to prevent falling off while attaching to the blub. It is also feasible to accommodate a glass or dichroic to fit in as well. Black coating finish.

Coolite series gooseneck lamps can be suited to lighting equipment, console, mixer and lighting cabinet rack or whatever a low light application needed. There are traditional halogen lamp (CH series) and innovation detachable LED (CL series) type. Both types are available in 12" and 18" length. Black finished as standard. XLR (3 Pin), XLR right angle (3 Pin) and BNC connectors are standard connectors, please specify when order.



HALOGEN LAMP

CH series have 8 mm diameter gooseneck and 12V / 5W high intensity lamp.



LED

CL series have 5 mm diameter gooseneck and 4 LED lamp DC12V 40mA 0.5W



MOBILE HALOGEN LAMP

CH series have 8mm diameter gooseneck and 12V/5W high intensity replaceable lamp head.



BNC CONNECTOR

CH-12B
12" with BNC connector.

CL-12B
12" with BNC connector.

CH-12BM
12" with BNC connector.

CH-18B
18" with BNC connector.

CL-18B
18" with BNC connector.

CH-18BM
18" with BNC connector.



XLR 3 PIN CONNECTOR

CH-12X
12" with XLR 3 Pin connector.

CL-12X
12" with XLR 3 Pin connector.

CH-12XM
12" with XLR 3 Pin connector.

CH-18X
18" with XLR 3 Pin connector.

CL-18X
18" with XLR 3 Pin connector.

CH-18XM
18" with XLR 3 Pin connector.



XLR 3 PIN RIGHT ANGLE CONNECTOR

CH-12XR
12" with XLR 3 Pin right angle connector.

CL-12XR
12" with XLR 3 Pin right angle connector.

CH-12XRM
12" with XLR 3 Pin right angle connector.

CH-18XR
18" with XLR 3 Pin right angle connector.

CL-18XR
18" with XLR 3 Pin right angle connector.

CH-18XRM
18" with XLR 3 Pin right angle connector.



CL-712

Portable LED Table Lamp runs on 3 x AA1.5V batteries (included).



LGN-917

12" Gooseneck 3-pin XLR with on/off switch (LED head light).



CH-212

Rack Lighting with Double Gooseneck lamp Dimmer on-off switch 19" wide x 1.75".



LGN-9001

XLR female connector type Dimmer on-off Switch



LGN-9003

BNC female connector type Dimmer on-off Switch



LGN-0202

12V5W halogen bulb high intensity.



LGN-2203

Power adaptor 120V to 12V



LGN-2200

Power adaptor 230V to 12V



LGN-0200

5W halogen bulb.

PC-30 portable mini console is a six-fader compact and handy DMX-512 lighting controller. Constructed with a lightweight plastic hard case, this small console is suitable for any handheld applications on the go. It is a simple and reliable console to control your lights.

Dimension: 24 x 19.8 x 10.8cm



YOUTUBE
KUPO PC-30 PORTABLE
MINI LIGHTING CONSOLE



YOUTUBE
KUPO PC-30 PORTABLE
MINI LIGHTING CONSOLE
(OPERATION)



PC-30 Portable Mini Console

Input Voltage: DC/7-9V
Output Current: 350mA
Power Consumption: 5W
Control: DMX-512
Fader: 6
DMX Channel: 30

Display: 4 digits LED display
Storage Capacity: 2048kb
Programmable scene: 5
Programmable Step: 99
N.W.: 1.3kg

Features

1. Compact and portable with plastic hard case.
2. Powered by 18650 rechargeable battery, or a 110-240V AC power supply.
3. DMX levels are set by six faders; each fader has an associated bump button.
4. Up to 30 DMX channels with patchable button setting.
5. On-board switch for setting signal output as 3pin XLR or wireless antenna.
6. Equipped with aluminum V-lock wedge, for attaching the console to the stand or truss easily through Super Convi Clamp with V-lock base (KCP-739)
7. Dimension: 24 x 19.8 x 10.8cm

DX-1220 and DX-1230 are digital DMX-512 modular dimmer pack, built up for 12-channel x 20A per pack or 30A per pack. They are ideal and reliable for theatre, concert hall, hotel, conference center, museum and art gallery, cinema, department store, entertainment center, disco night club, as well as architectural lighting design. A variety of functional and testing keys to help get maximum usage. Modular design enables you to change the modular pack without removing the whole unit.

Features

1. 12 individual extractable modules with 12-channel control.
2. DMX-512 and analog input.
3. A MCB (NFB) for each channel.
4. Output for each channel can be limited to protect the lamp.
5. Emergent scene setting function to output scene data when losing DMX control signal.
6. Thermo-controlled fan will be activated when the temperature is over 37°C; cease the output when over 63°C and restart below 60°C.
7. Self-testing function to test without a console.
8. Options of dimming or switch for each channel.

Specification

- Power: AC 100-240V; 45-63Hz, 3 phase 4 wire (other spec upon request)
- Protocol: DMX-512
- DMX signal connection: XLR 5-pin
- Analog signal input: DC / 0-10V
- Analog signal channel: 12 channel (pin1-pin12:CH1-CH12, pin15:GND)
- Analog signal connection: D type plug 15-pin
- Installation: 19" 4U standard rack
- Dimension: 482 (W) x 176 (H) x 297 (D) mm
- Weight: 21kgs (DX-1220); 21.5 kgs (DMX-1230)



DX-1220 Lighting Control System

12 Channel DMX Dimmer Pack; Maximum Output 20A Per Channel.



DX-1230 Lighting Control System

12 Channel DMX Dimmer Pack; Maximum Output 30A Per Channel.



DX-404 DMX Dimmer Pack

- Maximum 5A per channel, total 15A
- DMX512 signal
- Most advanced 'C3' dimming curve
- 256 steps resolution
- DMX start addressing setting
- Channel output status preview
- Auto frequency tracking
- Warm-Up setting 0-6%
- Automatic warm up function, protects loads and extend the life of bulbs.

Structure

- Power AC 100-120V, AC 200-240V, 45-63Hz.
- Signal connector XLR 3 Pin, 6P4C (RJ11) telephone jack.
- Location TRUSS hanging or desktop operation.
- Dimension: 240(W) x 88(H) x 120(D) mm.
- Weight: 1.2 kg



DP-24 Interface

Decode DMX signal into analog signal, start channel selectable.

Data

- Power input AC 100-240V, 45-63Hz.
- Output channel 72 channels.
- DMX signal input / output DMX512 / 1990.
- DMX signal connection XLR 5 Pin.
- Analog signal output DC 0-10V.
- Analog signal output.
- Channel 01 to 24: Pin 1-24: CH01-24; Pin 25: GND
- Channel 25 to 48: Pin 1-24: CH25-48; Pin 25: GND
- Channel 49 to 72: Pin 1-24: CH49-72; Pin 25: GND
- Analog signal connection D-Type plug 25 Pin.
- Dimension: 482(W) x 44(H) x 240(D) mm.
- Rack size 19" 1U rack mountable.
- Weight: 2 kg



DP-81II DMX Splitter Panel

Data

- Power AC 100-240V.
- Control signal input 1PCS 5 Pin XLR female.
- DMX signal output / input DMX512 / 1990.
- Control signal output 8PCS 5 Pin XLR male.
- Dimension: 482(W) x 44(H) x 113(D) mm.
- Rack size 19" 2U rack mountable.
- Weight: 1.16 kg



CX-1C Tester

- Light & handy, portable.
- Available for testing synchroized signal DMX-in/ DMX-out.
- Build-in battery, it can work for several hours continuously (charge it 5hrs., it can work 3hrs. or waiting 100hrs.) LCD background lighting economizes on power to extend battery life.

Data

- Power DC 12V / 1A.
- Battery type AAA 1.2V 4PCS rechargeable.
- DMX signal output channel DMX512/ 1990.
- DMX signal connection XLR 5 Pin (x2)- phone jack RJ11 (x2).
- Dimension: 100(W) x 133(H) x 50(D) mm.
- Weight: 0.75 kg

Sleeping device

Stop working in 5min. running, it will be in the mode of sleeping to extend battery life.

DIGI-CHECK is designed for DMX diagnosis and cable tester. The smallest and compact device that combines detect unit and white LED torch light.

Feature

1. 9 LEDs indicate the status of DMX signal & data line in detail, Switch off automatically when suspending for 120 seconds; save battery life.
2. Easy to change battery without any tool.
3. Come with leather pouch and strap for max portability.
4. Aluminum housing, CNC treated, anodized, Bright LED torch light/ White, 3 PIN/ 5 PIN male & female XLR plug,
5. Low power consuming.

Function

- Embedded one white LED as a torch light, DMX-512 signal level and load analyser, Individual data line inspector, Installed data line inspector.
- Power DC 12V/1A.
- Battery type LR44 x 3 PCS rechargeable batteries.
- DMX signal output channel DMX512 / 1990.
- DMX signal connection XLR 5 pin (x2) - XLR 3 Pin (x 2).



YOUTUBE
KUPO DIGI-CHECK



DC-920 Digi-check / Multi-function DMX Tester

Description: 5 pin Digi-check / Dimension: 22 x 137 mm / Weight: 0.15kg / Battery: LR44 x 3PCS (included)

DC-930 Digi-check / Multi-function DMX Tester

Description: 3 pin Digi-check / Dimension: 22 x 137 mm / Weight: 0.15kg / Battery: LR44 x 3PCS (included)



Innovative Function

For those cables installed and not to have checkup, use one Digi-check at each end to implement inspection. (in such function, one XLR female adaptor will be required to use in the same time)



DS-TM3 DIGI-SIT / DMX Terminator (XLR 3 PIN)

DS-TM4 DIGI-SIT / DMX Terminator (XLR 4 PIN)

DS-TM5 DIGI-SIT / DMX Terminator (XLR 5 PIN)

Mounted resistor providing termination to DMX cable. Signal rescuer if inadequate DMX cable is used. Embedded red LED gives constantly voltage check. Die-casting cap with keyring hole leaves durability and portability to stagehand.

Dimension: 100(W) x 133(H) x 50(D) mm / Weight: 0.04kg

Is a powerful and versatile special wind machine designed for studios, theaters, theme parks, touring, photographic and more. It is suitable for wide range application including blowing haze, smoke, bubbles, confetti or snow, cooling performers, dimmer racks or amplifiers even drying paint in studio. DF-500 can be controlled through standard DMX signal or master/slave operation through data link. Versatile yoke for overhead rigging, floor sitting or stand mounting. Housing is constructed from a molded lightweight plastic venting device with rugged tubular steel surrounded for transport and protection. The 11" one-piece blade and spiral front grill for creating narrow focus wind stream. Compact, lightweight and powerful.



YOUTUBE
DMX WIND MACHINE

Specification

- Power input: 100-240V AC, 1200W, Current Max. 10A.
- Motor: 500W, Max. 3200RPM.
- DMX mode: DMX on-off and volume control.
- Memory: 9 mode memory setting available.
- One touch turbo function: 0-3200RPM within 5 sec.
- Air volume: 1700CBM / hr .
- Wind speed: 60KM / hr .
- Remote controller: Supplied w/3M cable.
- Built-in master / slave control interface.
- Dimension: 480 x 560 x 460 mm.
- Weight: 12.5 kg.

DF-500 DMX Fan Machine

Four reasons DigiFan makes a vortex wind effect

Always put the fan behind the smoke source so as to not gum up the fan with fluid.



11" one piece deep pitch blade churn through the air, maximizing the amount of the air moved with the each turn of powerful motor.

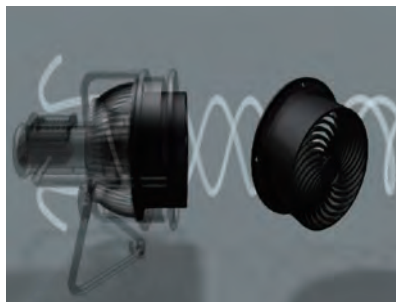

The spiral shape designed front grill offset the direction of the air as it twists off the blade. This allows the air to travel long distance.



Air inlet duct tube ensures that the deep blade are fully enclosed in a cylindrical duct, air is sculped into a column (beam of air).



To combine deep pitch blade, spiral grill, ducted tube and a switching power supply the multi function Digi fan is able to create a fully controllable vortex wind effect.



Multi functional control box for Manual, DMX and Program setting.



Switch for local or DMX operation mode.



Switching power supply with aluminum enclosure.



On/Off switch, universal 100-240V power input and fuse protection.



Molded plastic venting encompassed by rugged steel frame.



Sitting on floor by its own floor stand.



Sitting on stand with 28mm spigot.



Rigging on truss through the 13mm hole with M12 bolt coupler in the center of the bracket plate.



Industrial grade 500W, Max. 3200RPM Motor.



Locking knob with bearing for tighten yoke and adjusting direction.



11" one piece deep pitch blade.



Link
Master and Slave - Up to 9 Fans can be locally controlled by one controller using DMX data link.

Dimension

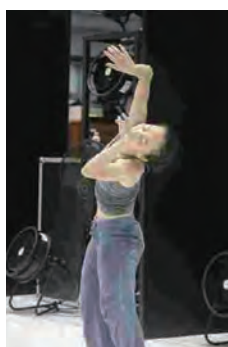
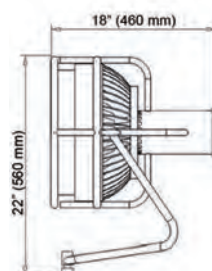
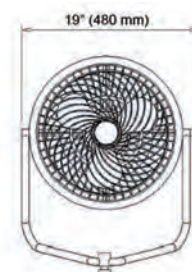

Apart from conventional one, DMX mirror ball motor offers a flexible and selective control for the rotation, and generates much more diverse effects. It is compatible with standard DMX-512, and runs for 2 channels. The metal chassis is compact and sturdy, and also comes with a M10 fixing hole on top of bracket which makes installation easy and fast. It is designed to fit wide range of mirror ball size up to diameter 50 cm.

Specification

- Power Input: AC90-250V 60 Hz.
- Power Consumption: 10W (Max).
- Fuse: 3 A.
- DMX Channel: 2 channels (one for motor / one for power output).
- Power output: 60 W (Max).
- Max Load: Dia. 50 cm (20") mirror ball.

Features

1. Runs for 3 functions: DMX, stand-alone, master-slave.
2. Two DMX channels: channel one is output control where you could plug in lamp up to 60 W; channel two is motor control for controlling motor travel from 0.5RMP to 5R MP, for clockwise or counterclockwise rotation.
3. DMX-512 control: fully compatible with standard DMX protocol. The LED indicator will flash with 2 Hz while receiving the correct data.
4. Master-Slave: Any unit of the link can act as a master, and make the others in this link run synchronously. No controller or DMX signal is required in this mode.
5. Stand Alone: Speed and direction can be controlled by DIP switching.



MB-055 DMX Mirror Ball Motor



E0502 2" mirror ball

E0504 4" mirror ball

E0508 8" mirror ball

E0510 10" mirror ball

E0512 12" mirror ball

E0516 16" mirror ball

E0520 20" mirror ball

E0524 24" mirror ball

E0540 40" mirror ball

E0550 50" mirror ball

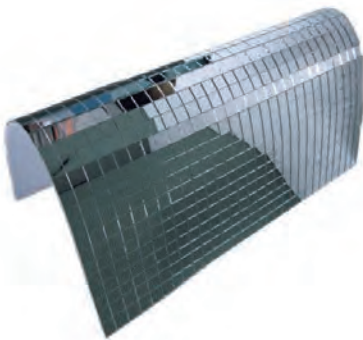

MM-1212 Mirror Mat for 12" x 12" Glass

- 12 inch x12 inch flexible mirrored tiles sheet.
- Attach to walls, cylinders and more.
- Glass tiles 1.1 cm x 1.1 cm.
- Double sided tape .

Mirror Ball Motor



MBM-01
For 8"-20"
mirror ball



MBM-02
For 24"-30"
mirror ball



MBM-03
or 40"-60"
mirror ball

Goreal intercom system, including headset, belt pack and power station, is designed to fulfill the requirement for entertainment. It is a system featuring portable, compact, plug-n-play with no complicated settings. This system is ideal for the live event while the local communication is required, and making the communication clear, authentic and real-time.

Headset

The sophisticated headset with 270 degree rotatable mic provides greatest convenience for operation. Simply swing mic boom upward or downward to turn on or switch off the talking mode. Soft synthetic leather, complete embraced ear muffs, and adjustable headband makes the listening comfortable. Noise-proof and reliable.



GR-801 Single Muff



GR-802 Double Muff



YOUTUBE
GOREAL INTERCOM
SYSTEM: HEADSET



SPECIFICATION

Headphones Type	Circumaural, closed-back
Sensitivity	90dB SPL
Frequency Response	20-20,000 Hz
Max. Input Power	100mW
Rated Impedance	400Ω
Microphone Element	Dynamic
Frequency Response	150-10,000 Hz
Polar Pattern	Cardioid
Rated Impedance	250Ω
Open Circuit Sensitivity	-60 dBV/Pa (1.0mV/PA) ±3dB, at 1KHz
MAX. SPL:	136dB SPL (THD≤1%, at 1KHz)
Distortion	<3%
Connector/Cable	4Pin/1.6M

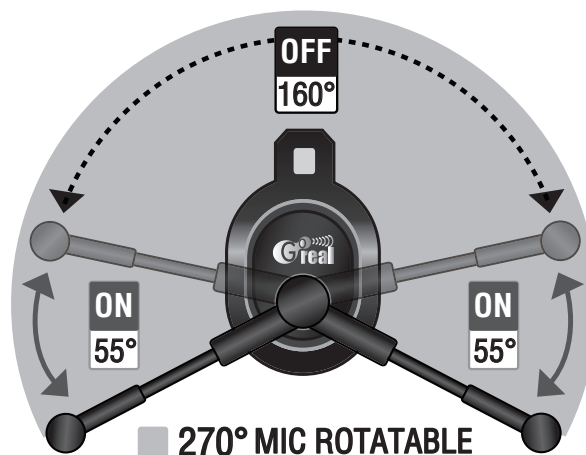
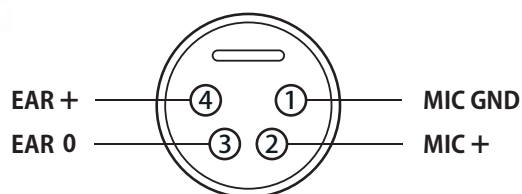

Belt pack is made of sturdy aluminum alloy housing making it much durable in touring. The rear metal clip makes this unit to hang on the wall or attach to the belt easily. The illuminating CALL button makes it pretty visible in the dark backstage. MIC button is made with bright yellow for easy identification. It comes with 3pin and 4pin socket connectors for interconnection.



GR-BP01 Belt Pack



- 1. "MIC" button
- 2. Voice (sidetone) level knob
- 3. Listen level knob
- 4. "CALL" indicator
- 5. Outlet for headset
- 6. Inlet for circuit cabling
- 7. Outlet for next belt pack

The housing of power station is made of robust aluminum alloy extrusion. No worry for the AC power as it takes universal input (90-240V). Two circuits for respective maneuver, or looping them all in one group for real-time communication for maximum 20 units of belt pack (GR-PS01). It comes with 3pin socket connectors for interconnection.



GR-PS01 Power Station

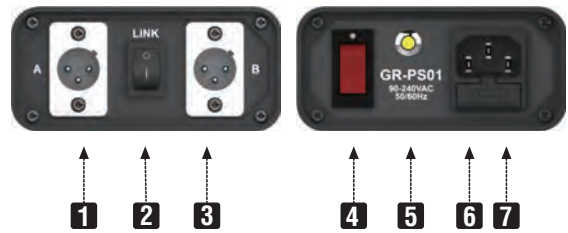

- 1. Outlet for circuit A
- 2. On/Off switch for circuit A+B
- 3. Outlet for circuit B
- 4. On/Off switch for main input
- 5. Main power indicator
- 6. Main power inlet
- 7. Fuse socket

SPECIFICATION

Power Requirement	24-30VDC
Earphone Output	200Ω
Microphone Input	200Ω dynamic
Measurement	106 x 113.5 x 52.7 mm
Weight	0.42 kgs

SPECIFICATION

Input Voltage	90-240VAC, 50/60Hz (0.8A/115VAC, 0.56A/230VAC)
Output Voltage	Max. DC/27V, 1.7A
Measurement	106 x 269 x 45 mm
Weight	0.86 kgs

Same as GR-PS01 for working with universal power input (90-240V), this power station powers up to 60 units of belt pack in same time for operation. Three channels A/B/C can be linked up as A+B, or B+C, or put them all together A+B+C for larger group. It is made to fit standard 19" rack. Low profile and compact.

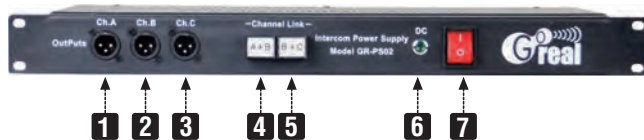

- 1. Channel A outlet for belt packs
- 2. Channel B outlet for belt packs
- 3. Channel C outlet for belt packs
- 4. Link up Channel A and B
- 5. Link up Channel B and C
- 6. LED indication for power status
- 7. AC power switch

When these two buttons are pressed, Channel A, B, C are all linked up all together.

GR-PS02 Power Station



SPECIFICATION

Input Voltage	90-240VAC (50/60Hz)
Output Voltage	Max. DC / 24-27V, 3.8A
Measurement	45 x 480 x 230 mm
Weight	3.5 kgs



www.fortlamps.ru +7495 749 66 09 info@fortlamps.ru

KUPO CO., LTD (Headquarters)
Tel : +886-2-2999-1906
Fax: +886-2-2999-1955
E-mail: stage@kupo.com.tw

**6F, No 4, Lane 609, Sec.5, Chung Shin Rd., San Chung District,
New Taipei City 24159, Taiwan**

Kupo Shanghai (Branch office)
Tel : +86-21-5677-9636

www.stage.com.tw

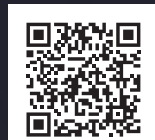

Product catalog download

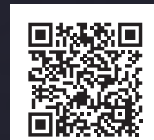

Product video channel

[NOTE] Whilst every effort has been made to ensure the accuracy of the information / material contained within this catalogue, Kupo does not accept any liability for errors or omissions. Specifications and technical data are provided for guidance purposes only. To improve products, we reserve the right to make any variation in design or construction to the equipment description without prior notice.

www.fortlamps.ru